

# VELIA

LED LINEAR SYSTEM



Easier installation,  
greater design freedom.

# VELIA

Easier installation,  
greater design freedom.

VELIA is the linear lighting solution designed to naturally blend into interior projects where design, functionality, and versatility are key elements.

Its essential aesthetics and rectangular shape enable the creation of elegant, continuous compositions that perfectly align with the needs of any environment.

The family includes four standard lengths (600, 1200, 1500, and 1800mm) and two finishes (black and white), making it easy to integrate into different spaces.

One of VELIA's main features is its quick and simple installation, along with the ease of expanding, adapting, or reconfiguring the system as project requirements evolve. Its modular concept allows profiles to be joined in a quick, precise and intuitive manner, optimising assembly time and simplifying the entire installation process.

This flexibility is complemented by another of the series' key concepts: a family developed from a common body, designed as a base to generate multiple solutions with different diffusers: opal, microprismatic, honeycomb, louvre, grille or wall washer.

Furthermore, in terms of sustainability, it optimises materials and streamlines components, creating efficient solutions.

This approach allows VELIA to be adapted to various requirements for efficiency, visual comfort, lighting effect and finish, maintaining aesthetic consistency throughout the project.

With a comprehensive range of connectors – L, 120°, T, Y and X – VELIA not only enables the creation of continuous lines of light, but also offers the freedom to create more dynamic, creative and customised compositions for any space.

Available for surface-mounted, suspended or wall-mounted installation, VELIA combines design, functionality and custom configurations within a single series. This makes it the ideal solution for projects that require versatile and modern linear lighting.

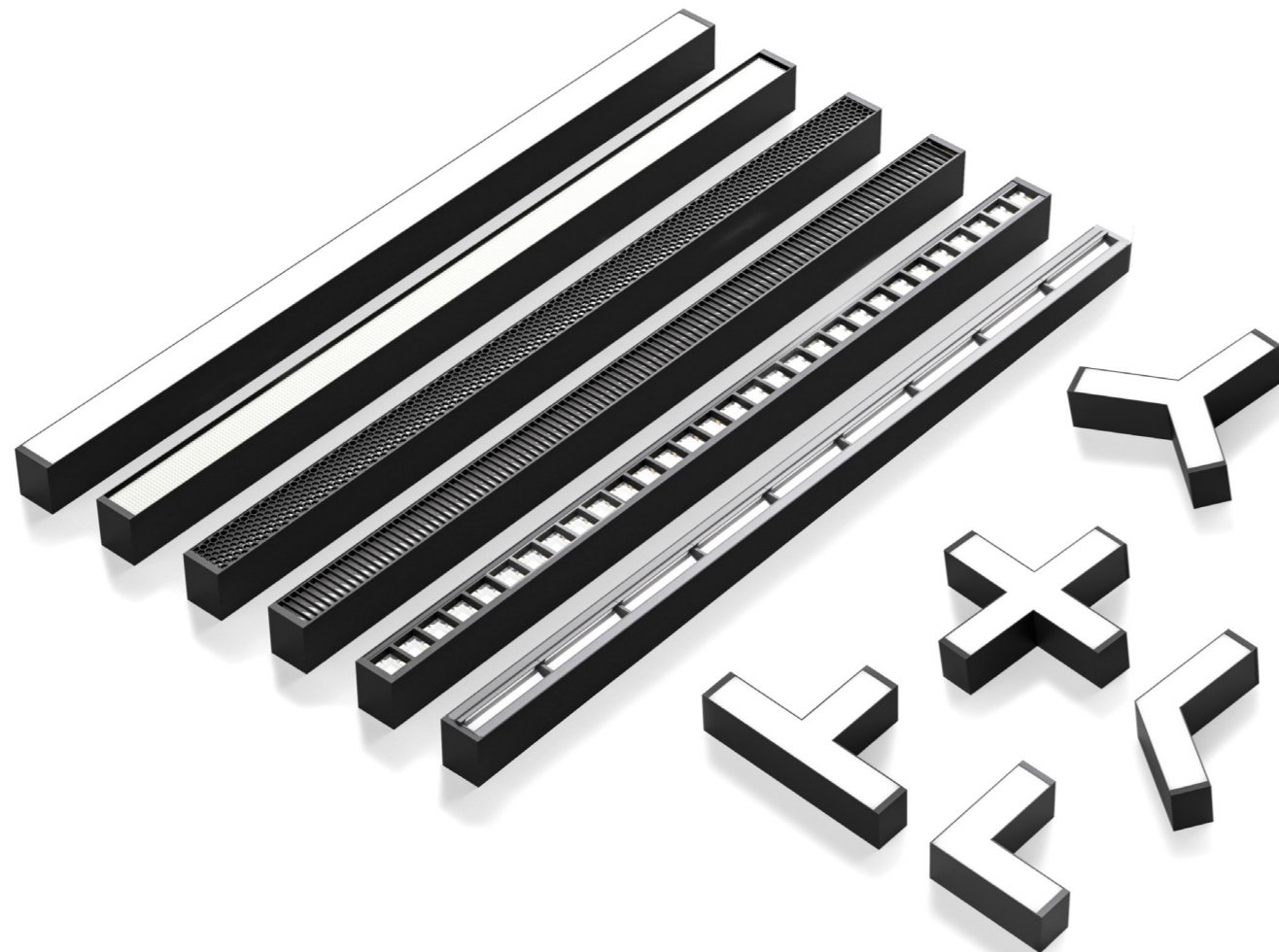

## VELIA. FEATURES

	VELIA OPAL VLA OP		VELIA MICRO- PRISMATIC VLA MP		VELIA HONEYCOMB VLA HN		VELIA LOUVRE VLA LV		VELIA GRILLE VLA GR		VELIA WALL WASHER VLA WW	
POWER / LENGTH	W	mm	W	mm	W	mm	W	mm	W	mm	W	mm
	20	616	20	616	20	616	20	616	20	616	20	679
	40	1216	40	1216	40	1216	40	1216	40	1216	40	1210
	50	1516	50	1516	50	1516	50	1516	—	—	—	—
	60	1816	60	1816	60	1816	60	1816	—	—	—	—
EFFICIENCY	Up to 114 lm/W		Up to 110 lm/W		Up to 28 lm/W		Up to 50 lm/W		Up to 120 lm/W		Up to 76 lm/W	
CCT SWITCH	● 3000K / ● 4000K / ● 5700K											
FINISH	White (RAL 9003) / Black (RAL 9005)											
BEAM ANGLE	110°		90°		48°		60°		80°		80°	
UGR			<19		<19		<19		<19			
DIMMING OPTIONS	1-10V / PUSH						DALI-2 / PUSH					
LIFETIME	50.000 h L80B50											
CRI	>80											
IP	IP20											
FLICKER	Flicker-Free											
OPERATING TEMPERATURE	-20°C ~ +40°C											
INSTALLATION TYPE (ACCESSORIES)	Surface / Suspension / Wall											
DIRECT CEILING INSTALLATION (WITHOUT ACCESSORIES)	✓		✓		✓		✓					
CONNECTORS	L / 120° / T / Y / X											
WARRANTY	5 years											

# VELIA. FEATURES



Up to  
actual  
120 lm/W

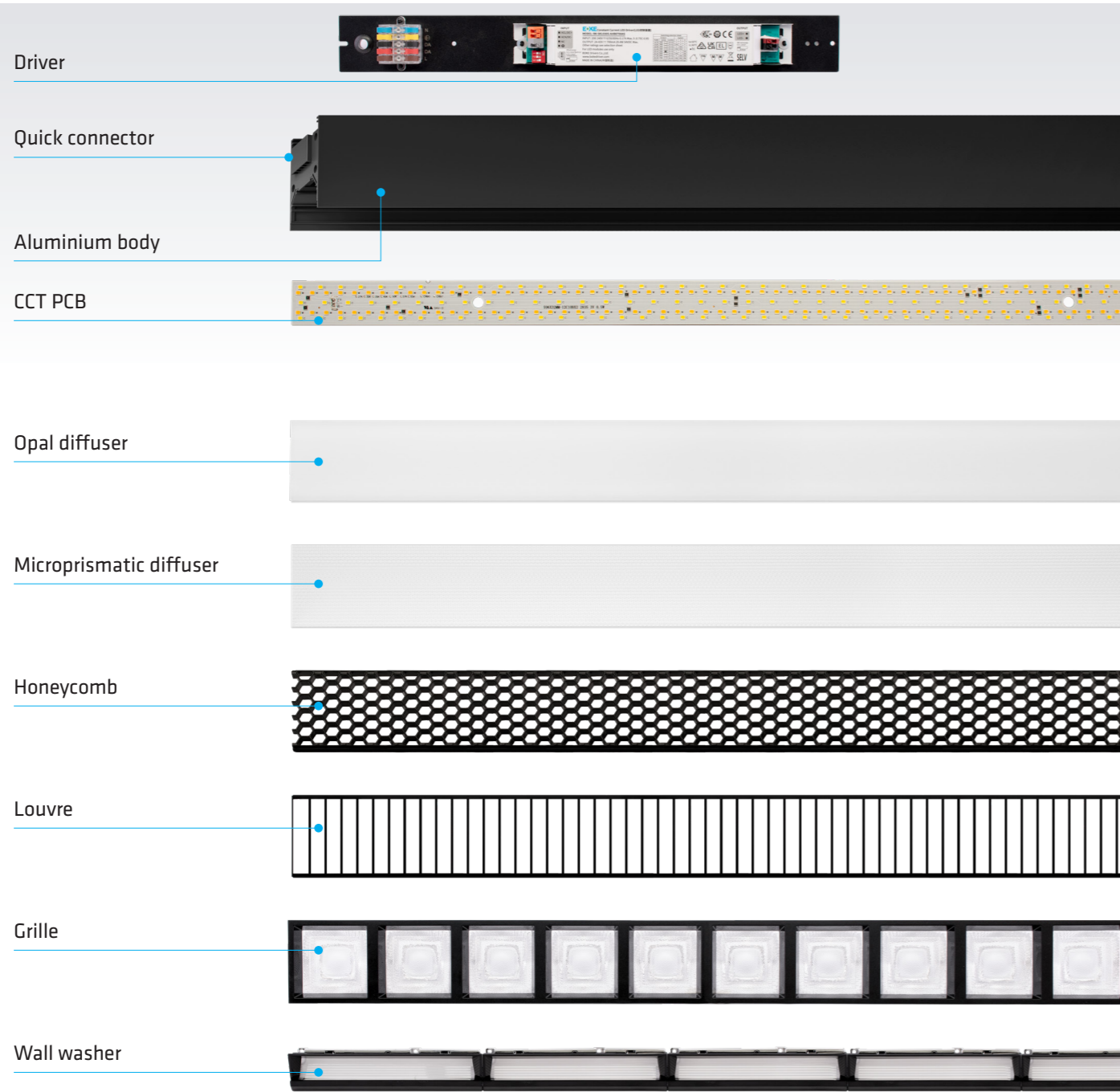

Driver

Quick connector

Aluminium body

CCT PCB

Opal diffuser

Microprismatic diffuser

Honeycomb

Louvre

Grille

Wall washer

### • CCT Switch

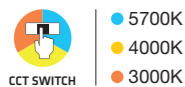

### • Beam angles



### • Dimming options



### • Optional



### • Material



### • Installation accessories

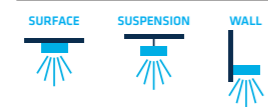

### • Connectors



# VELIA. FEATURES

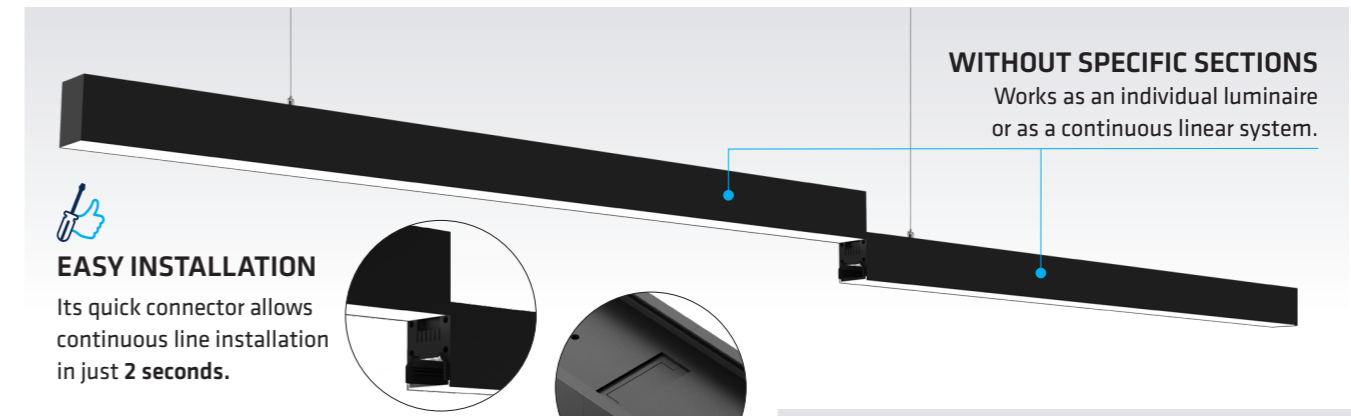

**WITHOUT SPECIFIC SECTIONS**  
Works as an individual luminaire or as a continuous linear system.



**EASY INSTALLATION**  
Its quick connector allows continuous line installation in just 2 seconds.



An accessory is included to prevent light leakage at the joints.

### INSTALLATION ACCESSORIES

#### SURFACE



#### SUSPENSION



#### WALL

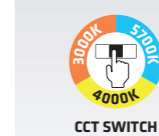

### CCT SWITCH

Top-mounted CCT switch to change the colour temperature between 3000K, 4000K and 5700K.

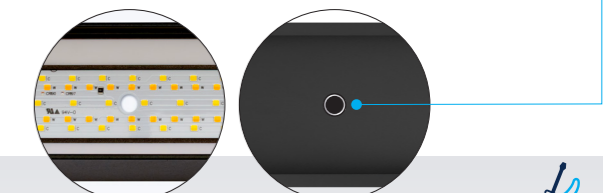

### DIRECT CEILING SURFACE MOUNTING

Featuring an internal hole for direct fixing to the ceiling, without the need for a surface-mounting accessory. (Except for Grille and Wall washer models)

### BLACK AND WHITE FINISH

All linear profiles and accessories are available in both finishes.



### CONNECTORS

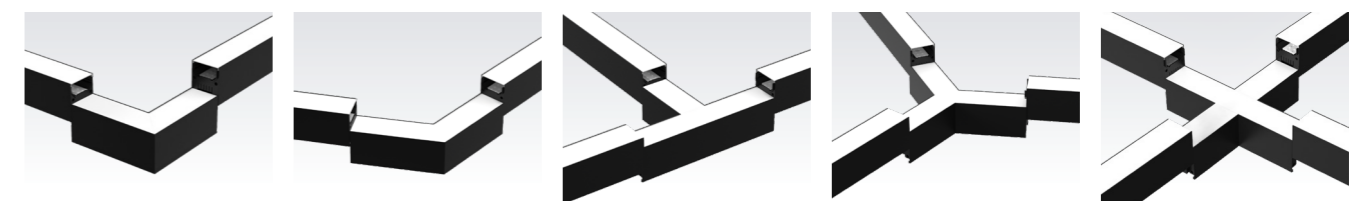

90° L CONNECTOR

120° CONNECTOR

T CONNECTOR

Y CONNECTOR

X CONNECTOR

# VELIA OPAL

## PRO VLA OP



### Material Certifications



### Dimming options Optional



### Installation accessories

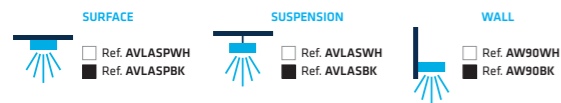

### Connectors (Pg. 12-14)

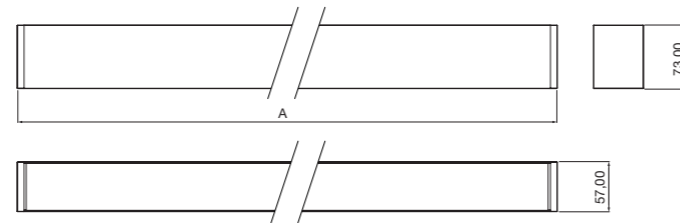
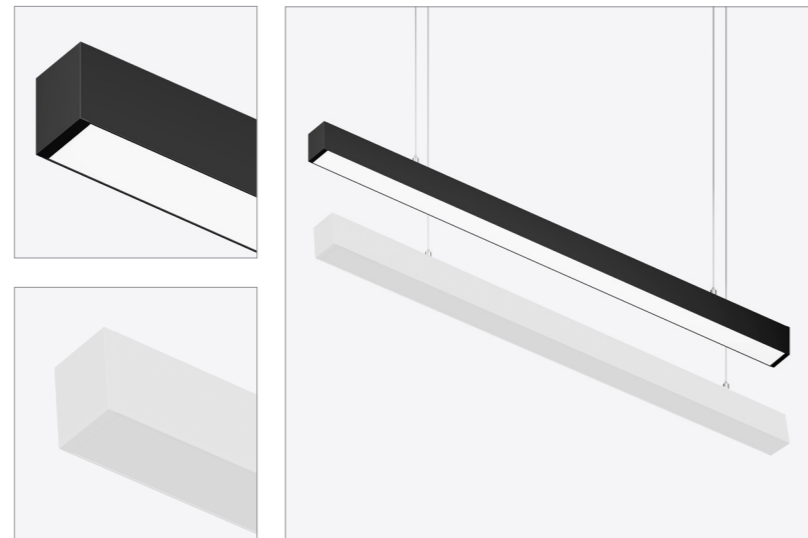
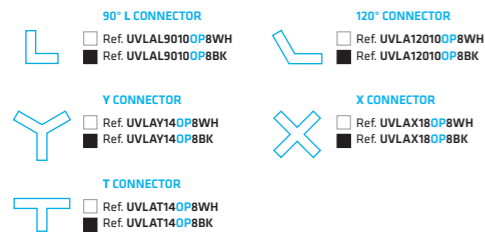

	A
VLA06	616
VLA12	1216
VLA15	1516
VLA18	1816

Measurements (mm).



Product Code	Options	W	CCT	2626 lm	2226 lm
VLA0620P8WH	* D1	20 W	● 5700K	2626 lm	2226 lm
VLA0620P8BK	* D2		● 4000K	2653 lm	2253 lm
			● 3000K	2460 lm	2160 lm
VLA1240P8WH	* D1	40 W	● 5700K	5232 lm	4432 lm
VLA1240P8BK	* D2		● 4000K	5344 lm	4544 lm
	* UE		● 3000K	4810 lm	4210 lm
VLA1550P8WH	* D1	50 W	● 5700K	6585 lm	5585 lm
VLA1550P8BK	* D2		● 4000K	6693 lm	5693 lm
	* UE		● 3000K	6097 lm	5347 lm
VLA1860P8WH	* D1	60 W	● 5700K	7898 lm	6698 lm
VLA1860P8BK	* D2		● 4000K	8016 lm	6816 lm
	* UE		● 3000K	7221 lm	6321 lm

\* Dimming options  
D1 1-10V / PUSH D2 DALI-2 / PUSH

\* Optional  
UE EU DRIVER

# VELIA MICROPRISMATIC

## PRO VLA MP



### Material Certifications



### Dimming options Optional



### Installation accessories

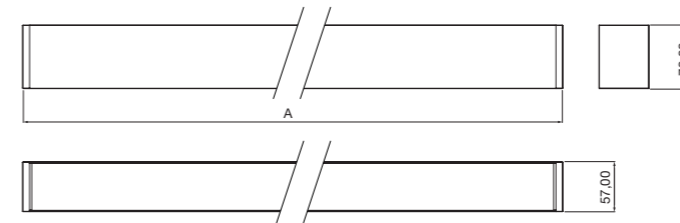
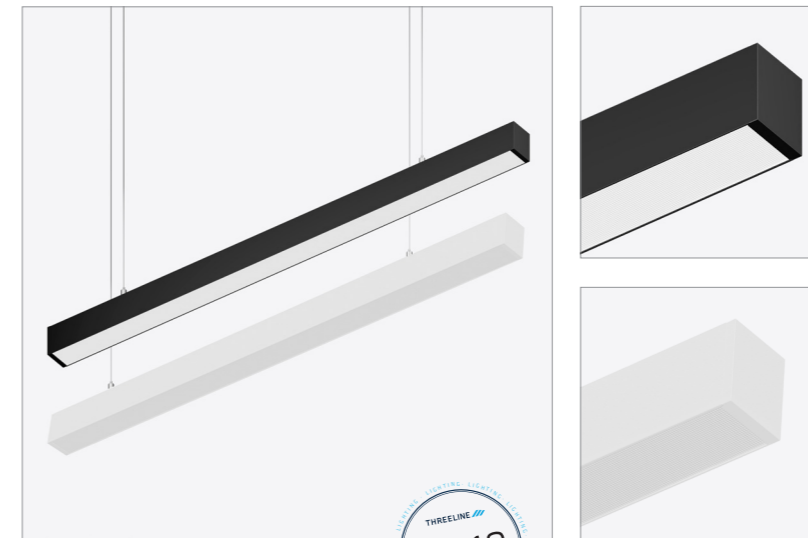
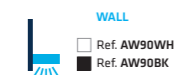

	A
VLA06	616
VLA12	1216
VLA15	1516
VLA18	1816

Measurements (mm).



Product Code	Options	W	CCT	2563 lm	2163 lm
VLA0620MP8WH	* D1	20 W	● 5700K	2563 lm	2163 lm
VLA0620MP8BK	* D2		● 4000K	2632 lm	2232 lm
	* UE		● 3000K	2406 lm	2106 lm
VLA1240MP8WH	* D1	40 W	● 5700K	4723 lm	3923 lm
VLA1240MP8BK	* D2		● 4000K	4989 lm	4189 lm
	* UE		● 3000K	4487 lm	3887 lm
VLA1550MP8WH	* D1	50 W	● 5700K	6325 lm	5325 lm
VLA1550MP8BK	* D2		● 4000K	6410 lm	5410 lm
	* UE		● 3000K	6025 lm	5275 lm
VLA1860MP8WH	* D1	60 W	● 5700K	7575 lm	6375 lm
VLA1860MP8BK	* D2		● 4000K	7800 lm	6600 lm
	* UE		● 3000K	7186 lm	6286 lm

\* Dimming options  
D1 1-10V / PUSH D2 DALI-2 / PUSH

\* Optional  
UE EU DRIVER

# VELIA HONEYCOMB

## PRO VLA HN

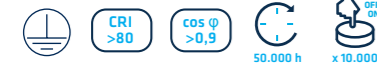

### Material



### Certifications

### Dimming options



### Optional



### Installation accessories

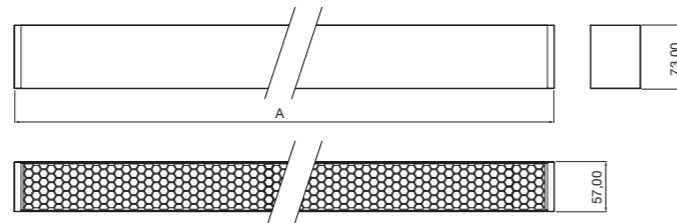
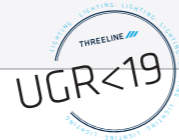
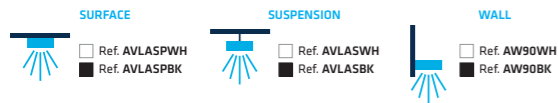

	A
VLA06	616
VLA12	1216
VLA15	1516
VLA18	1816

Measurements (mm).



III III	OPTIONS	W	CCT	897 lm	479 lm
VLA0620HN8WH	□ *	20 W	● 5700K	905 lm	505 lm
VLA0620HN8BK	■ *		● 4000K	795 lm	495 lm
			● 3000K		
VLA1240HN8WH	□ *	40 W	● 5700K	1970 lm	1170 lm
VLA1240HN8BK	■ *		● 4000K	1674 lm	1074 lm
			● 3000K		
VLA1550HN8WH	□ *	50 W	● 5700K	2452 lm	1452 lm
VLA1550HN8BK	■ *		● 4000K	2040 lm	1290 lm
			● 3000K		
VLA1860HN8WH	□ *	60 W	● 5700K	2881 lm	1681 lm
VLA1860HN8BK	■ *		● 4000K	2397 lm	1497 lm
			● 3000K		

\* Dimming options

D1 1-10V / PUSH D2 DALI-2 / PUSH

\* Optional

UE EU DRIVER

# VELIA LOUVRE

## PRO VLA LV



### Material



### Certifications

### Dimming options



### Optional



### Installation accessories

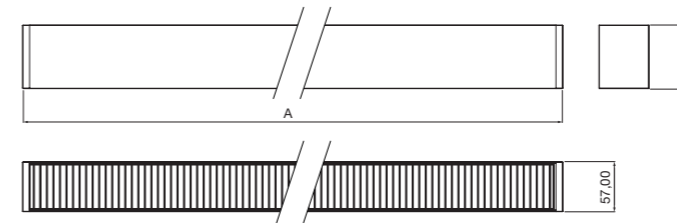
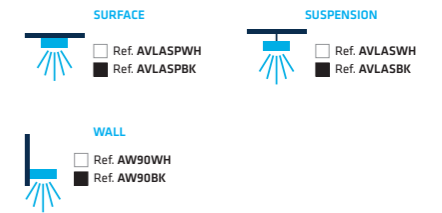

	A
VLA06	616
VLA12	1216
VLA15	1516
VLA18	1816

Measurements (mm).



III III	OPTIONS	W	CCT	1451 lm	1051 lm
VLA0620LV8WH	□ *	20 W	● 5700K	1457 lm	1057 lm
VLA0620LV8BK	■ *		● 4000K	1300 lm	1000 lm
			● 3000K		
VLA1240LV8WH	□ *	40 W	● 5700K	2534 lm	1814 lm
VLA1240LV8BK	■ *		● 4000K	2660 lm	1860 lm
			● 3000K	2308 lm	1708 lm
VLA1550LV8WH	□ *	50 W	● 5700K	3398 lm	2398 lm
VLA1550LV8BK	■ *		● 4000K	3519 lm	2516 lm
			● 3000K	3026 lm	2276 lm
VLA1860LV8WH	□ *	60 W	● 5700K	4012 lm	2812 lm
VLA1860LV8BK	■ *		● 4000K	4204 lm	3004 lm
			● 3000K	3569 lm	2669 lm

\* Dimming options

D1 1-10V / PUSH D2 DALI-2 / PUSH

\* Optional

UE EU DRIVER

# VELIA GRILLE

## PRO VLA GR



### Material



### Certifications

### Dimming options



### Installation accessories

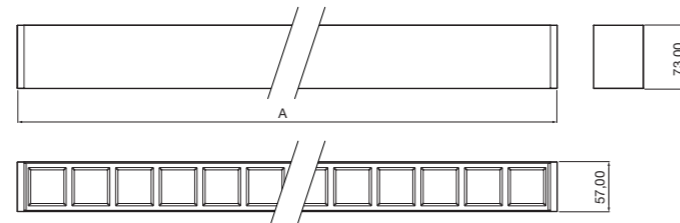
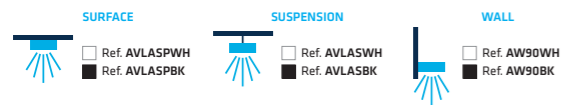

	A
VLA06	616
VLA12	1216

Measurements (mm).

# VELIA WALL WASHER

## PRO VLA WW



### Material



### Dimming options



### Installation accessories

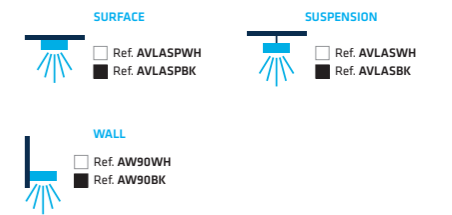

	A
VLA06	679
VLA12	1210

Measurements (mm).



CCT SWITCH

II III	OPTIONS	W	CCT	2616 lm	2324 lm
VLA0620GR8WH	<input type="checkbox"/> *	20 W	● 5700K	2616 lm	2216 lm
VLA0620GR8BK	<input checked="" type="checkbox"/> *		● 4000K	2324 lm	2324 lm
VLA1240GR8WH	<input type="checkbox"/> *	40 W	● 5700K	5246 lm	4446 lm
VLA1240GR8BK	<input checked="" type="checkbox"/> *		● 4000K	5172 lm	4792 lm
			● 3000K	2464 lm	2164 lm
			● 5700K	5246 lm	4446 lm
			● 4000K	5172 lm	4792 lm
			● 3000K	4972 lm	4372 lm

\* Dimming options

D1 1-10V / PUSH D2 DALI-2 / PUSH

\* Optional

UE EU DRIVER



CCT SWITCH

II III	OPTIONS	W	CCT	1819 lm	1419 lm
VLA0620WW8WH	<input type="checkbox"/> *	20 W	● 5700K	1819 lm	1419 lm
VLA0620WW8BK	<input checked="" type="checkbox"/> *		● 4000K	1927 lm	1527 lm
VLA1240WW8WH	<input type="checkbox"/> *	40 W	● 5700K	3609 lm	2809 lm
VLA1240WW8BK	<input checked="" type="checkbox"/> *		● 4000K	4001 lm	3201 lm
			● 3000K	1658 lm	1358 lm
			● 5700K	3609 lm	2809 lm
			● 4000K	4001 lm	3201 lm
			● 3000K	3326 lm	2726 lm

\* Dimming options

D1 1-10V / PUSH D2 DALI-2 / PUSH

\* Optional

UE EU DRIVER

## VELIA 90° L CONNECTOR

**PRO UVLA L90**

CCT SWITCH 220-240Vac 50/60Hz FLICKER FREE 110° 5 YEARS WARRANTY

CRI >80 COS φ >0,9 50.000 h x 10.000

IP20 DI WH BL RAL 9003 RAL 9005

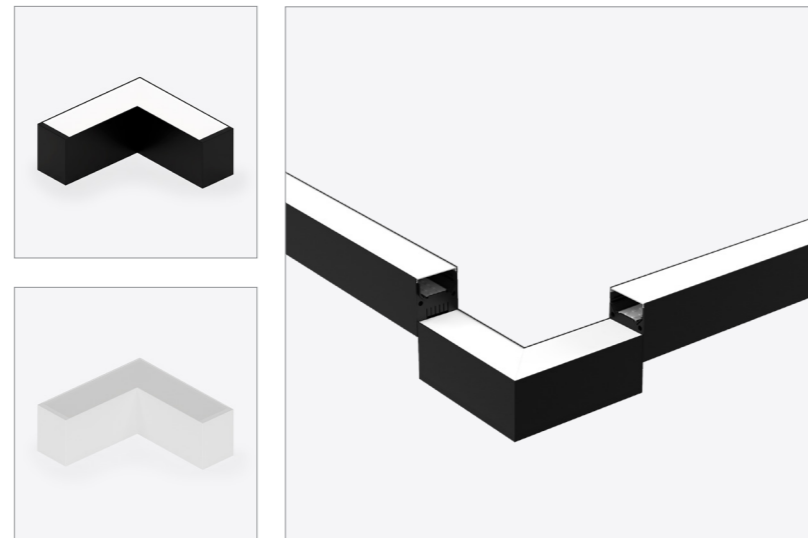
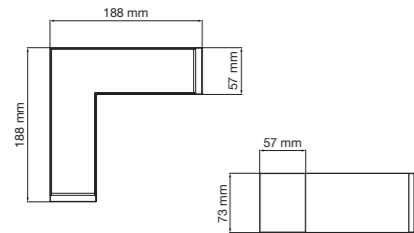

Color	W	CCT	lm	lm
UVLAL9010OP8WH	10 W	5700K	1286 lm	1086 lm
UVLAL9010OP8BK		4000K	1310 lm	1110 lm
UVLAL9010OP8BK		3000K	1208 lm	1058 lm

## VELIA 120° CONNECTOR

**PRO UVLA 120**

CCT SWITCH 220-240Vac 50/60Hz FLICKER FREE 110° 5 YEARS WARRANTY

CRI >80 COS φ >0,9 50.000 h x 10.000

IP20 DI WH BL RAL 9003 RAL 9005

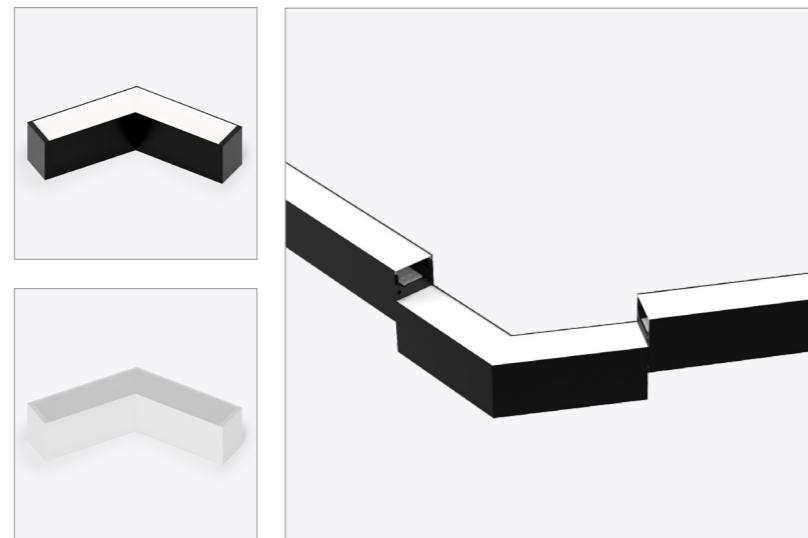
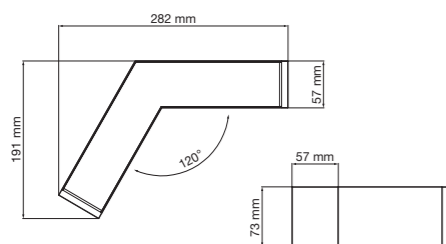

Color	W	CCT	lm	lm
UVLA12010OP8WH	10 W	5700K	1296 lm	1062 lm
UVLA12010OP8BK		4000K	1246 lm	1096 lm
UVLA12010OP8BK		3000K	1412 lm	1049 lm

### • Material



### • Certifications



### • Installation accessories

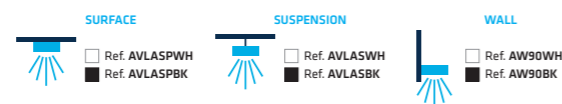

## VELIA T CONNECTOR

**PRO UVLA T**

CCT SWITCH 220-240Vac 50/60Hz FLICKER FREE 110° 5 YEARS WARRANTY

CRI >80 COS φ >0,9 50.000 h x 10.000

IP20 DI WH BL RAL 9003 RAL 9005

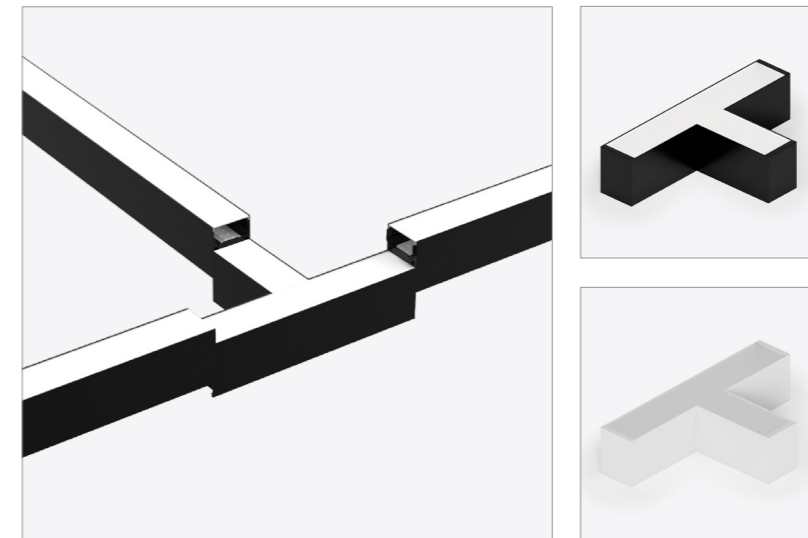
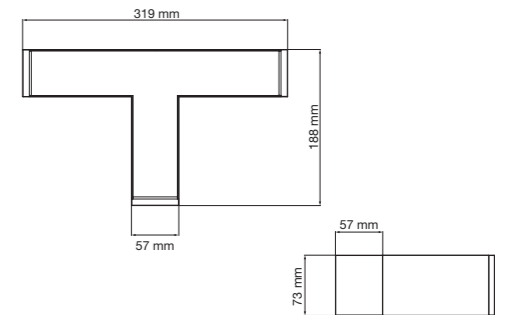

Color	W	CCT	lm	lm
UVLAT14OP8WH	14 W	5700K	1793 lm	1513 lm
UVLAT14OP8BK		4000K	1847 lm	1567 lm
UVLAT14OP8BK		3000K	1694 lm	1484 lm

## VELIA Y CONNECTOR

**PRO UVLA Y**

CCT SWITCH 220-240Vac 50/60Hz FLICKER FREE 110° 5 YEARS WARRANTY

CRI >80 COS φ >0,9 50.000 h x 10.000

IP20 DI WH BL RAL 9003 RAL 9005

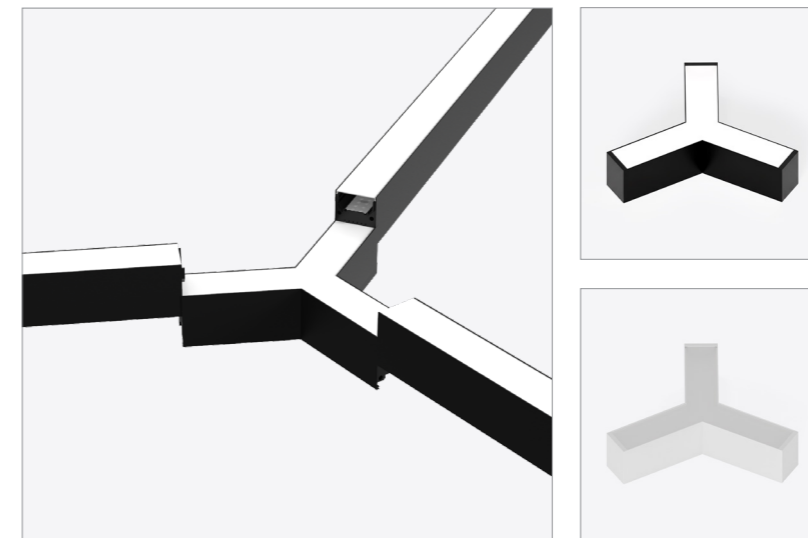
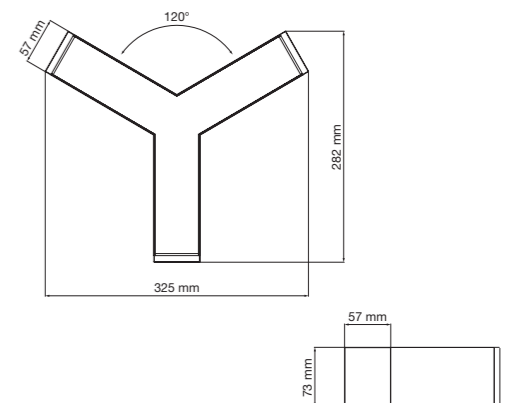

Color	W	CCT	lm	lm
UVLAY14OP8WH	14 W	5700K	1813 lm	1533 lm
UVLAY14OP8BK		4000K	1847 lm	1567 lm
UVLAY14OP8BK		3000K	1699 lm	1490 lm

### • Material



### • Certifications



### • Installation accessories

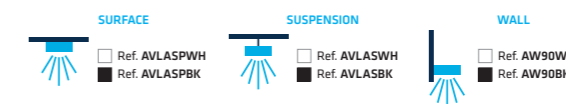

# VELIA X CONNECTOR

**PRO UVLA X**

- CCT SWITCH
- 220-240Vac 50/60Hz
- FLICKER FREE
- 110°
- 5 YEARS WARRANTY
- CRI >80
- cos φ >0,9
- 50.000 h
- x 10.000
- IP20
- DI RAL 9003
- BL RAL 9005
- NE

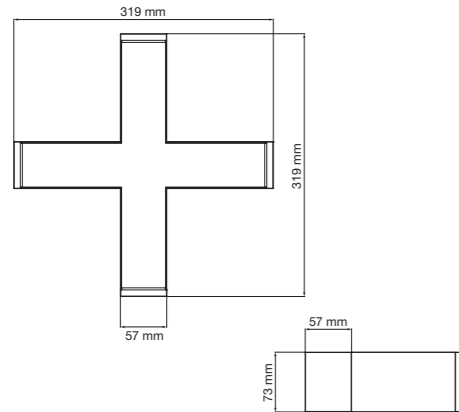
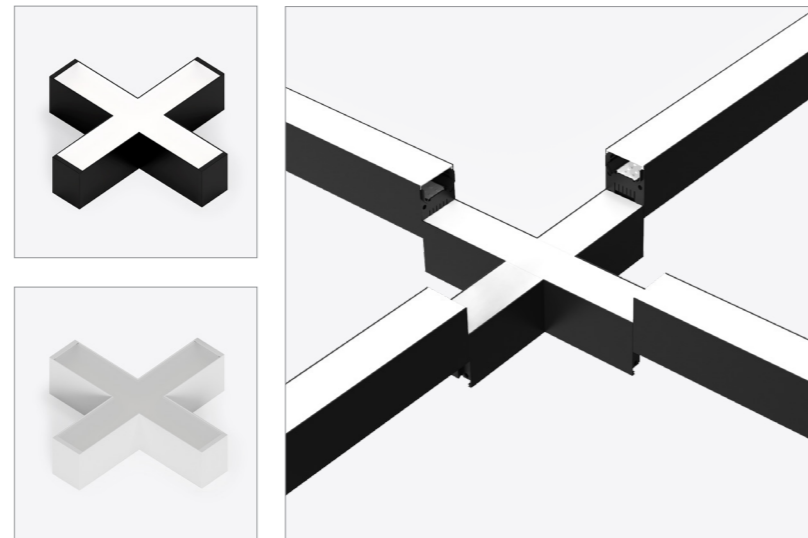

Model	Color	W	CCT	lm	lm
UVLAX180P8WH	White	18 W	5700K	2267 lm	1907 lm
UVLAX180P8BK	Black		4000K	2327 lm	1967 lm
			3000K	2141 lm	1871 lm

• Material



• Certifications



• Installation accessories

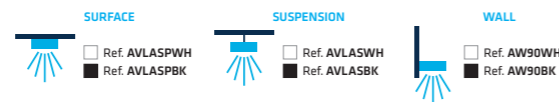

## VELIA INSTALLATION ACCESSORIES

**SURFACE**



- Ref. AVLASPWH (2 uds.)
- Ref. AVLASPBK (2 uds.)

**SUSPENSION**



- Ref. AVLASWH (2 uds.) 2.5 m cable.
- Ref. AVLASBK (2 uds.) 2.5 m cable.

**WALL**



- Ref. AW90WH (2 uds.)
- Ref. AW90BK (2 uds.)

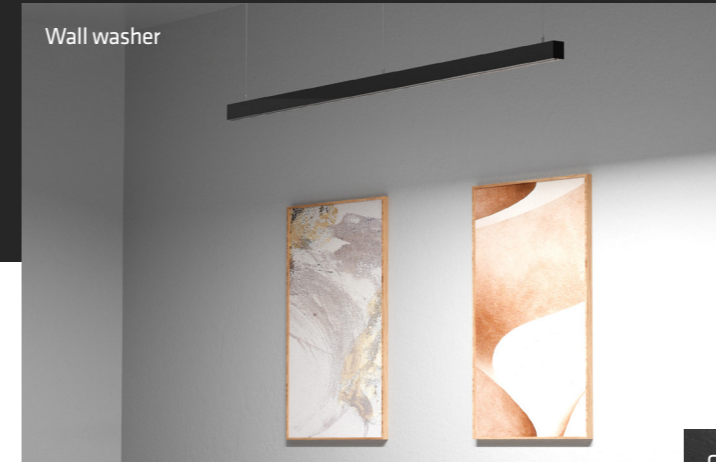
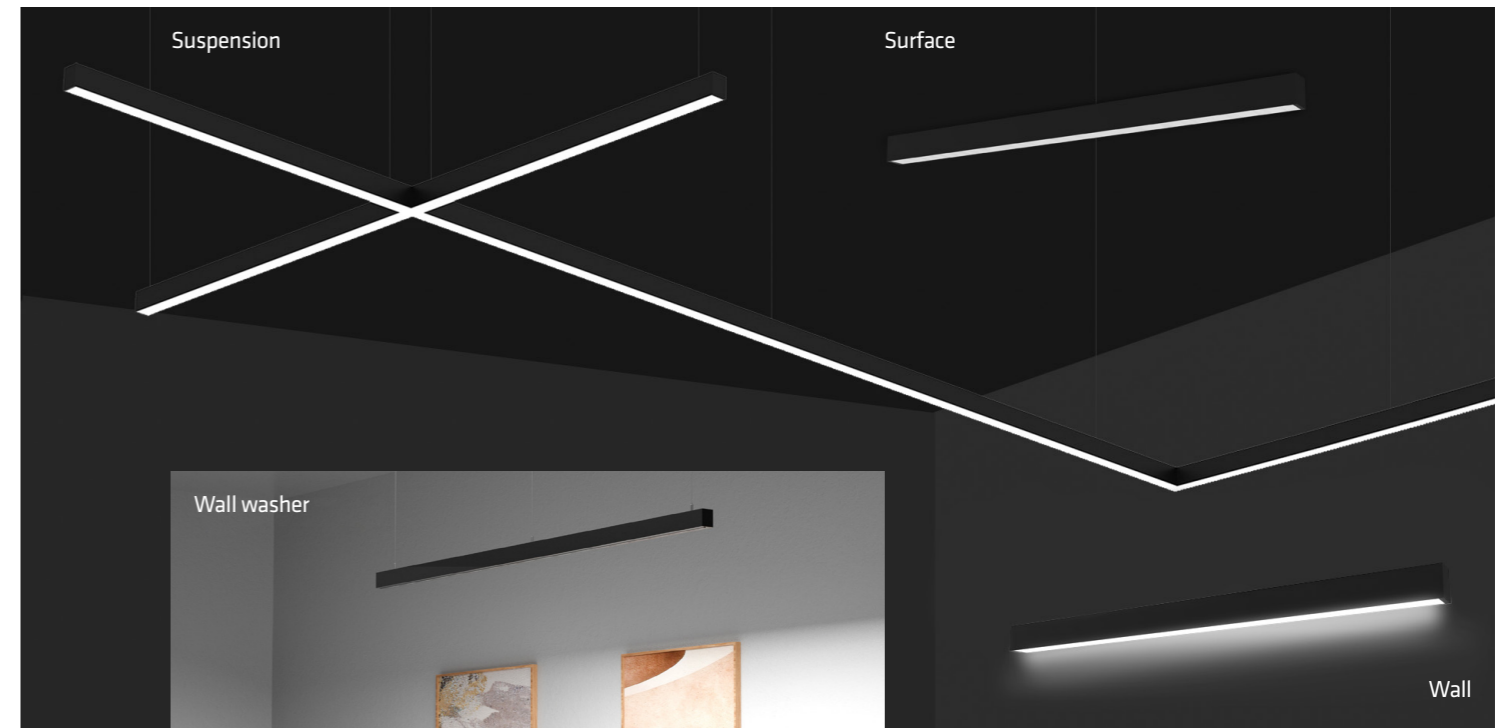

# VELIA

THREELINE 



[ThreelineGroup.com](https://ThreelineGroup.com)