

L I  B O

THREELINE 

24V

ULTRA THIN LINEAR TRACK | WOVEN TRACK

IIII	PG.
241X12C9300	60
241X12C9302	60
241X12CCT0	60
241X12CCT2	60
241X6C9300	60
241X6C9302	60
241X6CCT0	60
241X6CCT2	60
242X12C9300	61
242X12C9302	61
242X12CCT0	61
242X12CCT2	61
242X6C9300	61
242X6C9302	61
242X6CCT0	61
242X6CCT2	61
243R6C9300	58
243R6C9302	58
243R6CCT0	58
243R6CCT2	58
24AEC0	39
24AEC2	39
24BP9C9300	63
24BP9C9302	63
24BP9CCT0	63
24BP9CCT2	63
24C0	35
24C0-20	35
24C0CM	35
24C1	35
24C1-20	35
24C18C9300	50
24C18C9302	50
24C1CM	35
24C2	35
24C2-20	35
24C2CM	35
24C3	35
24C3-20	35
24C3CM	35
24C4	35
24C4-20	35
24C4CM	35
24C5	35
24C5-20	35
24C5CM	35
24C6C9300	64
24C6C9302	64
24C6CCT0	64
24C6CCT2	64
24CAB0	49
24CAB2	49
24CAC0	37
24CAC2	37

IIII	PG.
24CAU0	48
24CAU2	48
24D1000	46
24D1002	46
24D2000	46
24D2002	46
24E6C9300	62
24E6C9302	62
24E6CCT0	62
24E6CCT2	62
24ECC0	47
24ECC2	47
24ECL0	45
24ECL2	45
24ECLP0	45
24ECLP2	45
24ECR0	45
24ECR2	45
24ECRC0	45
24ECRC2	45
24ECRTA0	45
24ECRTA2	45
24FS6C9300	59
24FS6C9302	59
24FS6CCT0	59
24FS6CCT2	59
24G6C9300	52
24G6C9302	52
24L12C9300	54
24L12C9302	54
24L12CCT0	54
24L12CCT2	54
24L18C9300	54
24L18C9302	54
24L18CCT0	54
24L18CCT2	54
24L6C9300	54
24L6C9302	54
24L6CCT0	54
24L6CCT2	54
24LR12C9300	55
24LR12C9302	55
24LR12CCT0	55
24LR12CCT2	55
24LR18C9300	55
24LR18C9302	55
24LR18CCT0	55
24LR18CCT2	55
24LR6C9300	55
24LR6C9302	55
24LR6CCT0	55
24LR6CCT2	55
24NCF0	36
24NCF2	36

IIII	PG.
24NFO	38
24NF2	38
24O12C9300	56
24O12C9302	56
24O12CCT0	56
24O12CCT2	56
24O18C9300	56
24O18C9302	56
24O18CCT0	56
24O18CCT2	56
24O6C9300	56
24O6C9302	56
24O6CCT0	56
24O6CCT2	56
24OR12C9300	57
24OR12C9302	57
24OR12CCT0	57
24OR12CCT2	57
24OR18C9300	57
24OR18C9302	57
24OR18CCT0	57
24OR18CCT2	57
24OR6C9300	57
24OR6C9302	57
24OR6CCT0	57
24OR6CCT2	57
24PCC0	40
24PCC2	40
24S14C9300	65
24S14C9302	65
24S14CCT0	65
24S14CCT2	65
24S28C9300	65
24S28C9302	65
24S28CCT0	65
24S28CCT2	65
24SCLO	42
24SCL2	42
24SCLP0	42
24SCLP2	42
24SCR0	42
24SCR2	42
24SCRT0	42
24SCRT2	42
24SCRTA0	42
24SCRTA2	42
24SCT0	42
24SCT2	42
24SCX0	42
24SCX2	42
24SE18C9300	51
24SE18C9302	51
24TSCO	41
24TSC2	41

LIMBO Woven track

(ES) Cinta textil - (IT) Track tessile - (PT) Fita têxtil - (FR) Track textile



24C0

P. 35

24C1

P. 35

24C2

P. 35

24C3

P. 35

24C4

P. 35

24C5

P. 35

LIMBO Connection options

(ES) Opciones de conexión - (IT) Opzioni di collegamento - (PT) Opções de ligação - (FR) Options de connexion



24NCF

P. 36

24CAC

P. 37

24NF

P. 38



24AEC

P. 39

24PCC

P. 40

24TSC

P. 41

LIMBO 24V Ultra thin linear track

(ES) Carril ultrafino 24V - (IT) Binario lineare ultrasottile 24V
(PT) Calha ultrafino 24V - (FR) Rail ultra-mince 24V

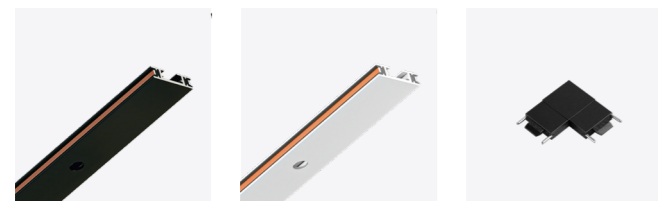

24SCR

P. 42

Accessories

Linear track accessory

(ES) Accesorio carril 24V - (IT) Accessorio binario lineare 24V
(PT) Acessório calha ultrafino 24V - (FR) Accessoire rail 24V



PRCLB19

P. 44

LIMBO 24V Recessed linear track

(ES) Carril de empotrar 24V - (IT) Binario lineare da incasso 24V
(PT) Calha de encastrar 24V - (FR) Rail encastré 24V



24ECR

P. 45

Accessories

LIMBO Power supplies 200W

(ES) Fuente de alimentación 200W - (IT) Driver 200W
(PT) Fonte de alimentação 200W - (FR) Alimentation 200W



24D200

P. 46

LIMBO Input module

(ES) Conector alimentación - (IT) Connett. alimentazione
(PT) Conector de alimentação - (FR) Connecteur d'alimentation



24CAU

P. 48

LIMBO Cone luminaire

(ES) Luminaria cono - (IT) Lampada cono
(PT) Luminária cone - (FR) Luminaire à cône

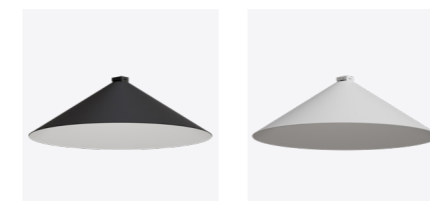

24C18

P. 50

LIMBO Power supplies 100W

(ES) Fuente de alimentación 100W - (IT) Driver 100W
(PT) Fonte de alimentação 100W - (FR) Alimentation 100W

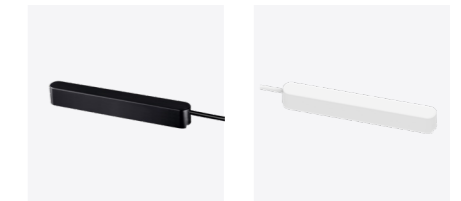

24D100

P. 46

LIMBO Power supplies Cable box

(ES) Embellecedor cubre cables - (IT) Accessorio copri fili
(PT) Embelezador para cobrir os cabos - (FR) Cache-câble

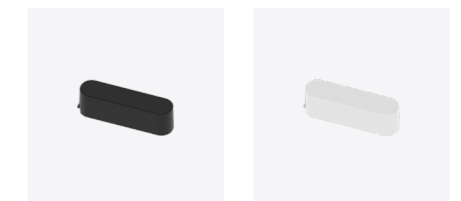

24ECC

P. 47

LIMBO Power module

(ES) Módulo de alimentación - (IT) Connettore di alimentazione
(PT) Módulo de alimentação - (FR) Module d'alimentation



24CAB2

P. 49

LIMBO Semi sphere luminaire

(ES) Luminaria semi esfera - (IT) Lampada semisfera
(PT) Luminária semi-esfera - (FR) Luminaire semi-sphérique



24SE18

P. 51

LIMBO Globe luminaire

(ES) Luminaria globo – (IT) Lampada globo
(PT) Luminária globo – (FR) Luminaire globe



24G6

P. 52

LIMBO Luminaires versions

(ES) Versiones de las luminarias – (IT) Versioni di lampade
(PT) Versões das luminárias – (FR) Versions des luminaires



CRI>90

CCT Switch

P. 53

LIMBO Adjustable tracklight

(ES) Foco tracklight orientable – (IT) Tracklight orientabile
(PT) Foco orientável para carril – (FR) Spot sur rail orientable

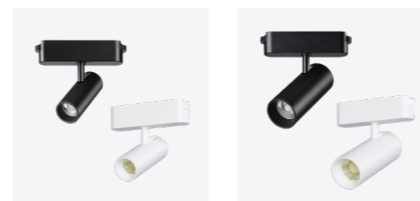

241X6

241X12

P. 60

LIMBO Adjustable double tracklight

(ES) Doble tracklight orientable – (IT) Doppio tracklight orientabile
(PT) Foco duplo orientável – (FR) Spot sur rail double direction



242X6

242X12

P. 61

LIMBO Linear light

(ES) Luminaria Lineal – (IT) Luce lineare
(PT) Luminária linear – (FR) Luminaire linéaire



24L6

24L12

24L18

P. 54

LIMBO Linear grille light

(ES) Luminaria lineal rejilla – (IT) Luce lineare fori
(PT) Luminária linear de grelha – (FR) Luminaire linéaire à grille



24LR6

24LR12

24LR18

P. 55

LIMBO Sphere luminaire

(ES) Luminaria esfera – (IT) Lampada sfera
(PT) Luminária esfera – (FR) Luminaire sphérique



24E6C9

P. 62

LIMBO Wall washer lamp

(ES) Bañador Pared – (IT) Wallwasher
(PT) Aplique de parede – (FR) Lèche-mur



24BP9

P. 63

LIMBO Linear folding light

(ES) Luminaria lineal orientable – (IT) Luce lineare orientabile
(PT) Luminária linear orientável – (FR) Luminaire linéaire orientable



24O6

24O12

24O18

P. 56

LIMBO Linear grille light

(ES) Luminaria lineal orientable rejilla – (IT) Luce lineare orientabile fori
(PT) Luminária linear orientável grelha – (FR) Luminaire linéaire à grille



24OR6

24OR12

24OR18

P. 57

LIMBO Cone luminaire

(ES) Luminaria cono – (IT) Lampada cono
(PT) Luminária Cone – (FR) Luminaire à cône

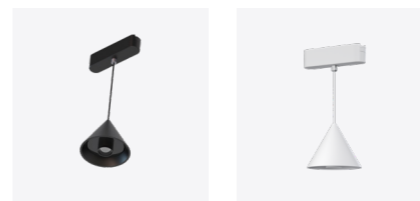

24C6C9

P. 64

LIMBO Silicon light

(ES) Silicon light – (IT) Silicon light
(PT) Luz de silicone – (FR) Luminaire silicone



24S14 / 24S18

P. 65

LIMBO Triple grille spotlight

(ES) Triple foco de rejilla – (IT) Faretto triplo
(PT) Foco triplo de grelha – (FR) Spot triple

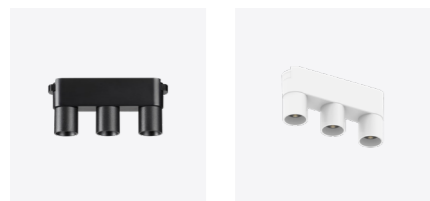

243R6

P. 58

LIMBO Surface mounted spotlight

(ES) Foco superficie – (IT) Faretto superficie
(PT) Foco de superfície – (FR) Spot surface



24FS6

P. 59

LIMBO Control options

(ES) Opciones de control – (IT) Opzioni di controllo
(PT) Opções de controlo – (FR) Options de contrôle



P. 66–67

LIMBO Installation examples

(ES) Ejemplos de instalación – (IT) Esempi di installazione
(PT) Exemplos de instalação – (FR) Exemples d'installation



Woven track

Linear track

P. 68–72

L I  B O

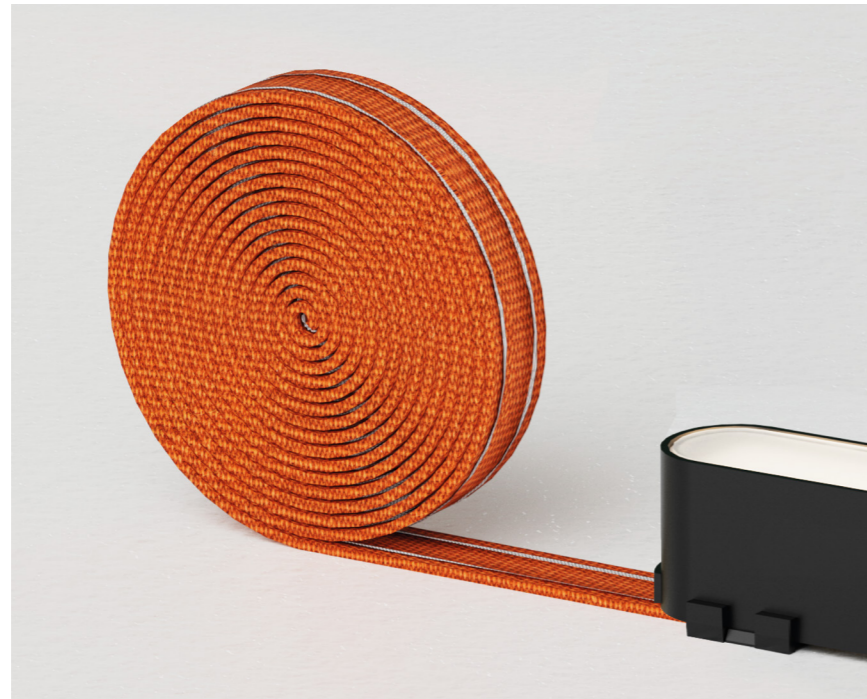

Beyond
the
Lighting

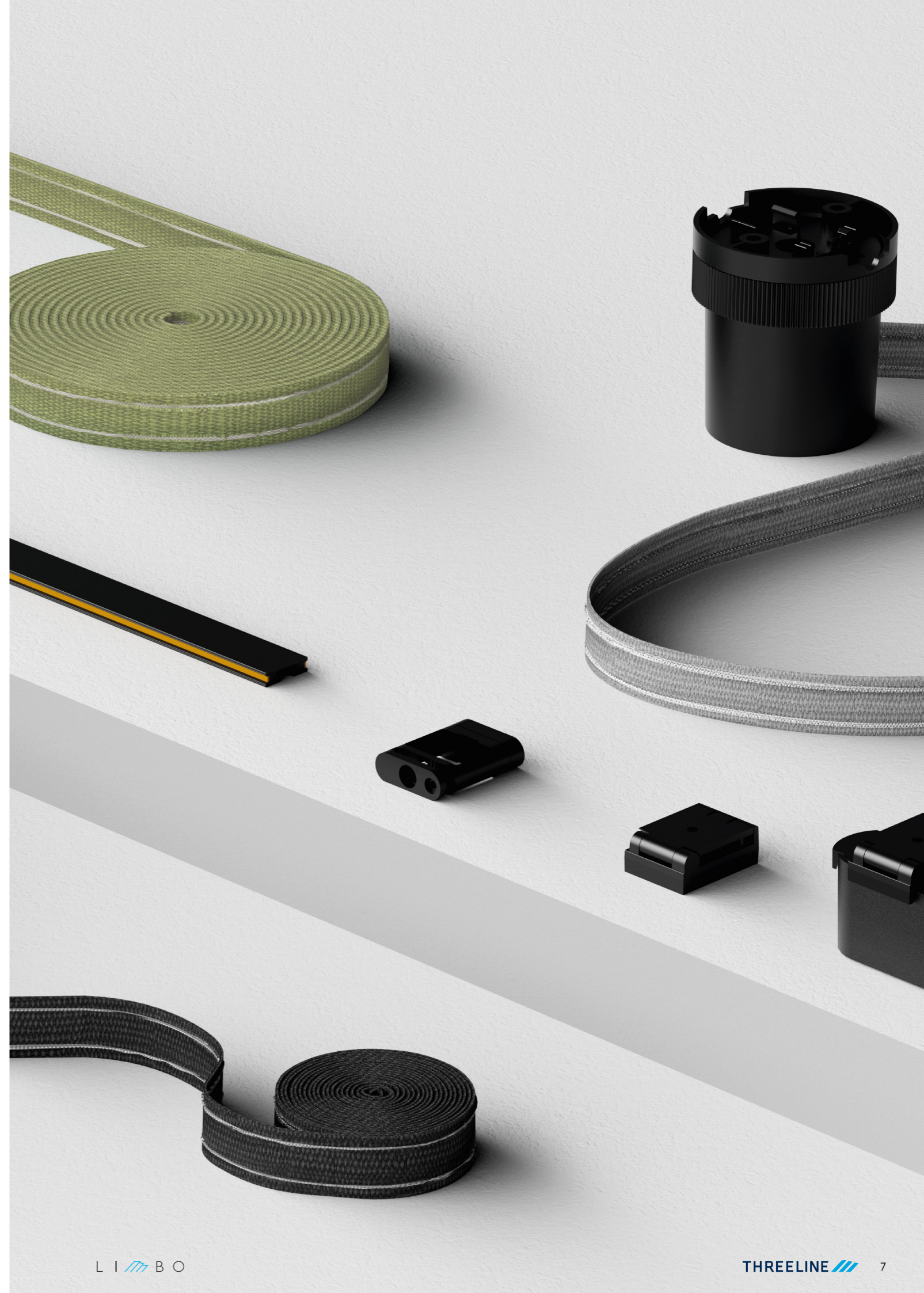

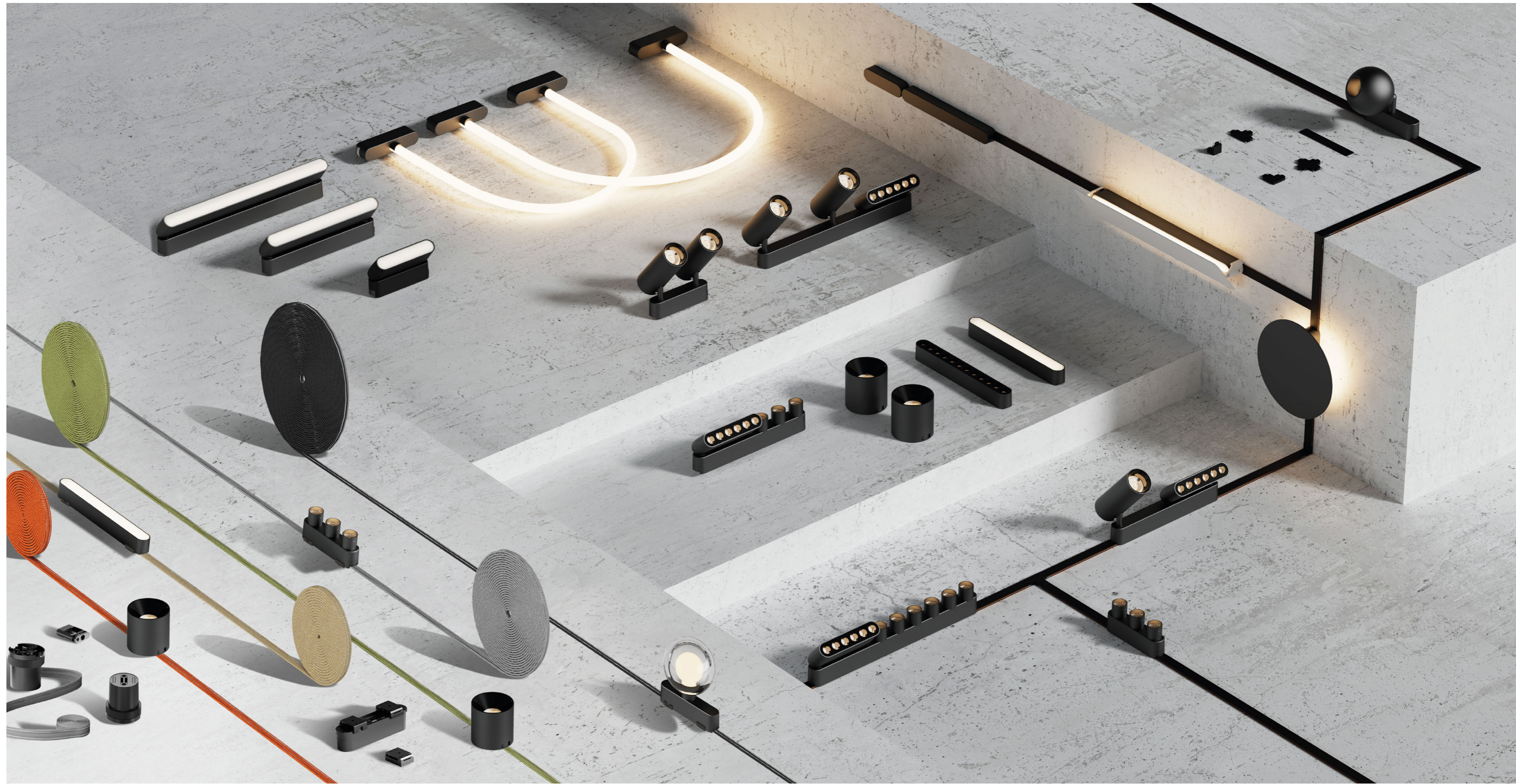

L I B O

Limbo is a versatile lighting system that takes the concept of lighting design to a new level.

Its ultra-thin rail and innovative conductive textile tape or textile track allow the free placement and sliding of the luminaires, offering unique and personalized solutions.

(ES) Limbo es un sistema de iluminación versátil que traslada el concepto de diseño lumínico a un nuevo nivel.

Su carril ultrafino y su innovadora cinta textil conductora o track textil, permiten la colocación y deslizamiento libre de las luminarias, ofreciendo soluciones únicas y personalizadas.

(IT) Limbo è un sistema di illuminazione versatile che porta il concetto di lighting design a un nuovo livello.

Il suo binario ultrasottile e l'innovativo 'track' tessile consentono il posizionamento e lo scorrimento libero delle lampade, offrendo soluzioni uniche e personalizzate.

(PT) Limbo é um sistema de iluminação versátil que eleva o conceito de design de iluminação a um novo nível.

A sua calha ultrafina e a sua inovadora fita têxtil condutora ou calha têxtil permitem a livre colocação e deslizamento das luminárias, oferecendo soluções únicas e personalizadas.

(FR) Limbo est un système d'éclairage polyvalent qui élève le concept de conception d'éclairage à un nouveau niveau.

Son rail ultra fin et son track textile conducteur innovant ou rail textile permettent le placement et le coulissement libres des luminaires, offrant des solutions uniques et personnalisées.







Transform the space

It redefines the way you interact with your surroundings, creating tailor-made compositions, from warm and welcoming environments to vibrant and lively spaces

It is ideal for any modern style, from offices and restaurants to private residences.

Transforma el espacio

(ES) Redefine la manera en la que interactuar con el entorno, creando composiciones hechas a medida, desde ambientes acogedores y cálidos hasta espacios vibrantes y llenos de vida.

Es ideal para cualquier estilo moderno, desde oficinas y restaurantes hasta residencias privadas.

Trasforma lo spazio

(IT) Ridefinisce il modo di interagire con l'ambiente tramite la creazione di composizioni su misura: atmosfere calde e accoglienti o spazi vibranti e pieni di vita.

Si adatta a qualsiasi stile moderno, da uffici e ristoranti ad abitazioni private.

Transforme o espaço

(PT) Redefine a forma como interagimos com o meio ambiente, criando composições à medida, desde ambientes acolhedores e aconchegantes a espaços vibrantes e cheios de vida.

É ideal para qualquer estilo moderno, desde escritórios e restaurantes a casas privadas

Transformez l'espace

(FR) Redéfinissez la manière d'interagir avec l'environnement, en créant des compositions sur mesure, allant d'environnements chaleureux et accueillants à des espaces vibrants et pleins de vie.

Idéal pour tout style moderne, des bureaux et restaurants jusqu'aux résidences privées.



Creativity without limits

Each element has been designed to give you complete control over the arrangement of light, making it ideal for those seeking a minimalist aesthetic.

In addition, it is compatible with 24V control systems.

Creatividad sin límites

(ES) Cada elemento ha sido diseñado para que tengas total control sobre la disposición de la luz, haciéndolo ideal para quienes buscan una estética minimalista.

Además, es compatible con los sistemas de control a 24V.

Creatività senza limiti

(IT) Ogni elemento è stato progettato per offrire totale libertà nella disposizione della luce, rendendolo perfetto per chi cerca un'estetica minimalista.

Inoltre, è compatibile con sistemi di controllo a 24V.

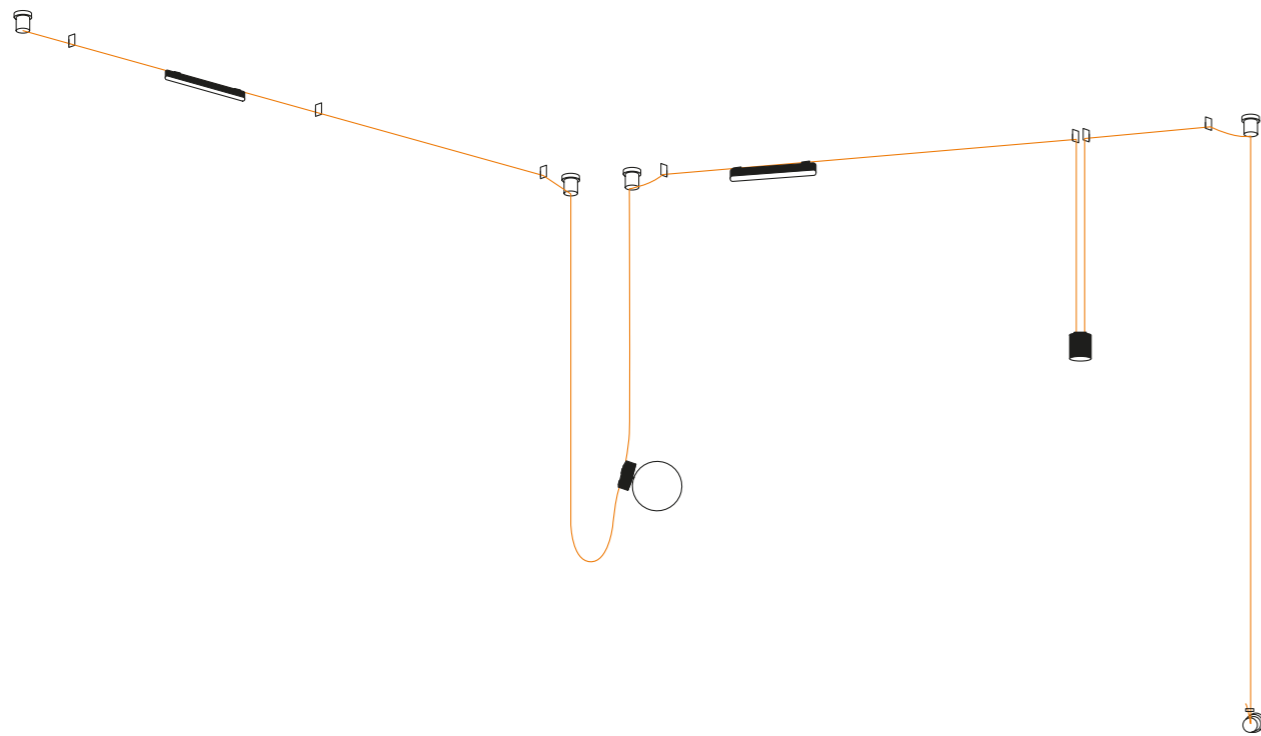

Criatividade sem limites

(PT) Cada elemento foi pensado para que tenha total controlo sobre a disposição da luz, sendo ideal para quem procura uma estética minimalista.

Além disso, é compatível com sistemas de controlo de 24V.

Créativité sans limites

(FR) Chaque élément a été conçu pour que vous ayez un contrôle total sur la disposition de la lumière, ce qui le rend idéal pour ceux qui recherchent une esthétique minimaliste.

De plus, il est compatible avec les systèmes de contrôle 24V.





Illuminate and decorate

Available in a wide variety of colors and luminaires, this system is both a decorative component and a high-tech lighting solution.

Ilumina y decora

(ES) Disponible en una gran variedad de colores y luminarias, este sistema es tanto un componente decorativo como una solución de iluminación de alta tecnología.

Ilumina e decora

(IT) Disponibile in un'ampia gamma di colori e con diversi tipi di corpi illuminanti, questo sistema è sia un elemento decorativo che una soluzione di illuminazione ad alta tecnologia.

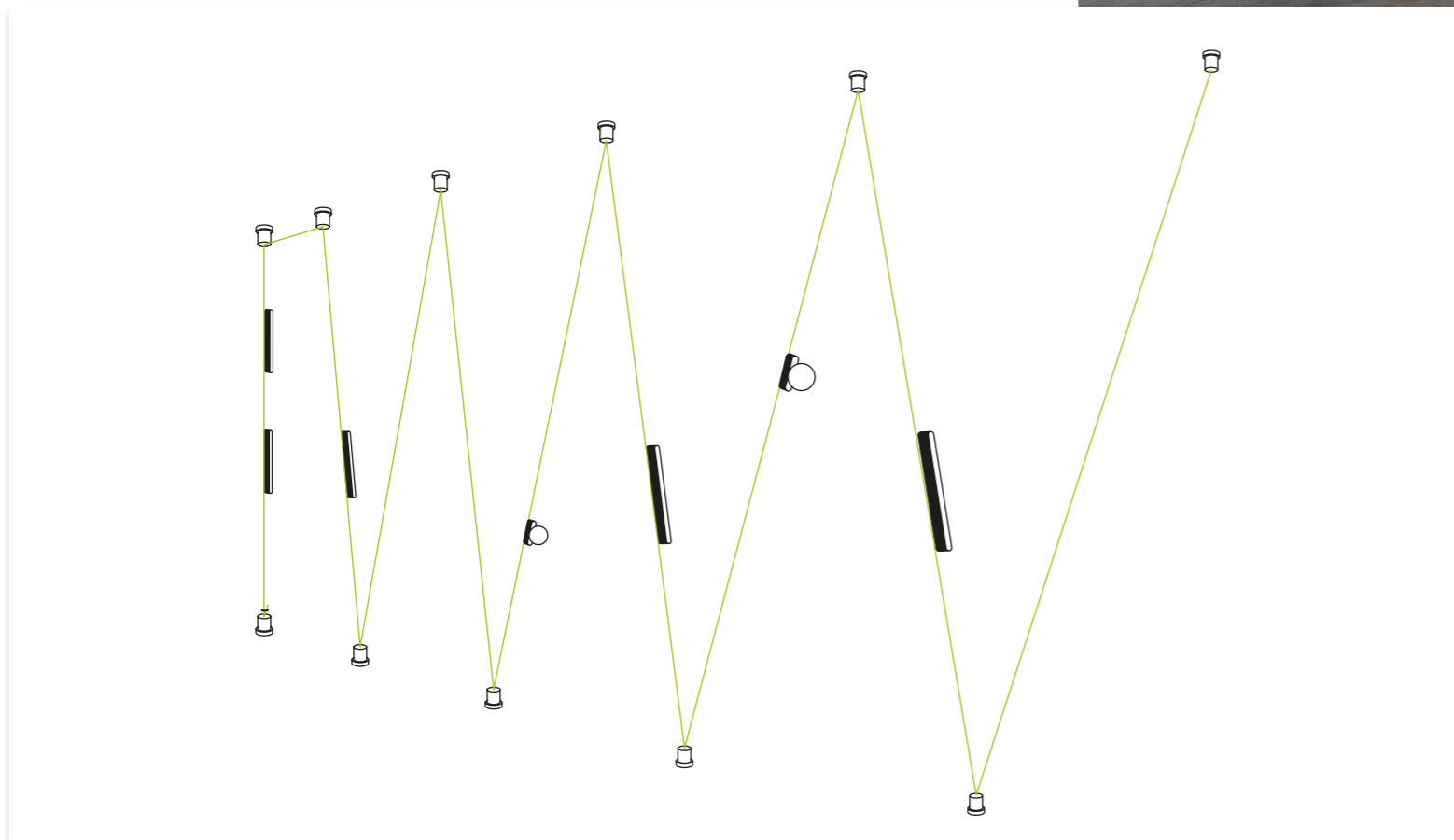

Iluminar e decorar

(PT) Disponível numa ampla variedade de cores e luminárias, este sistema é simultaneamente um componente decorativo e uma solução de iluminação de alta tecnologia.

Illuminer et décorer

(FR) Disponible dans une grande variété de couleurs et de luminaires, ce système est à la fois un élément décoratif et une solution d'éclairage de haute technologie.



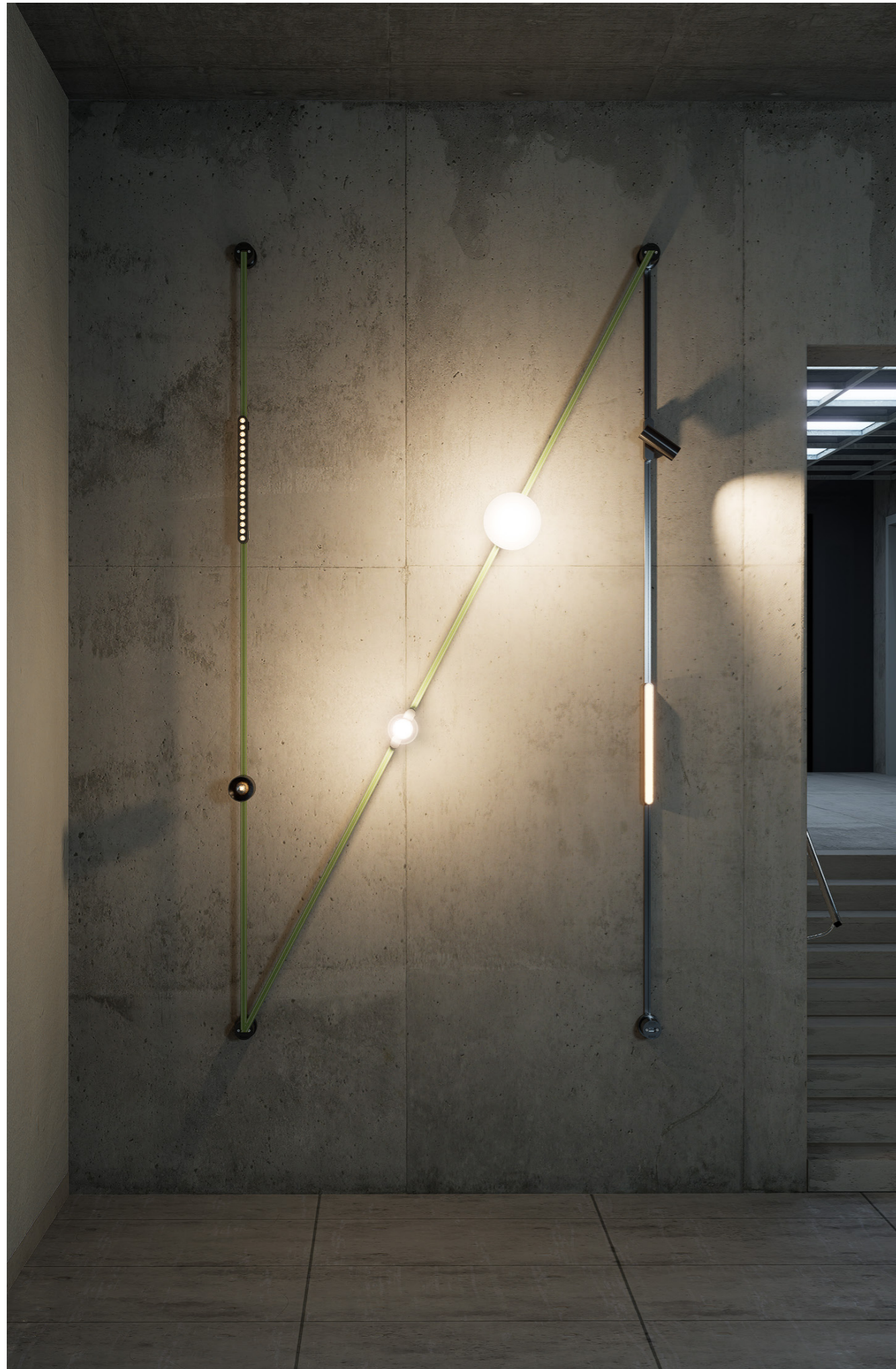





PRO LIMBO Woven track

(ES) Cinta textil - (IT) Track tessile - (PT) Fita Têtil - (FR) Track textile





 24V 9A MATERIAL CONDUCTIVE

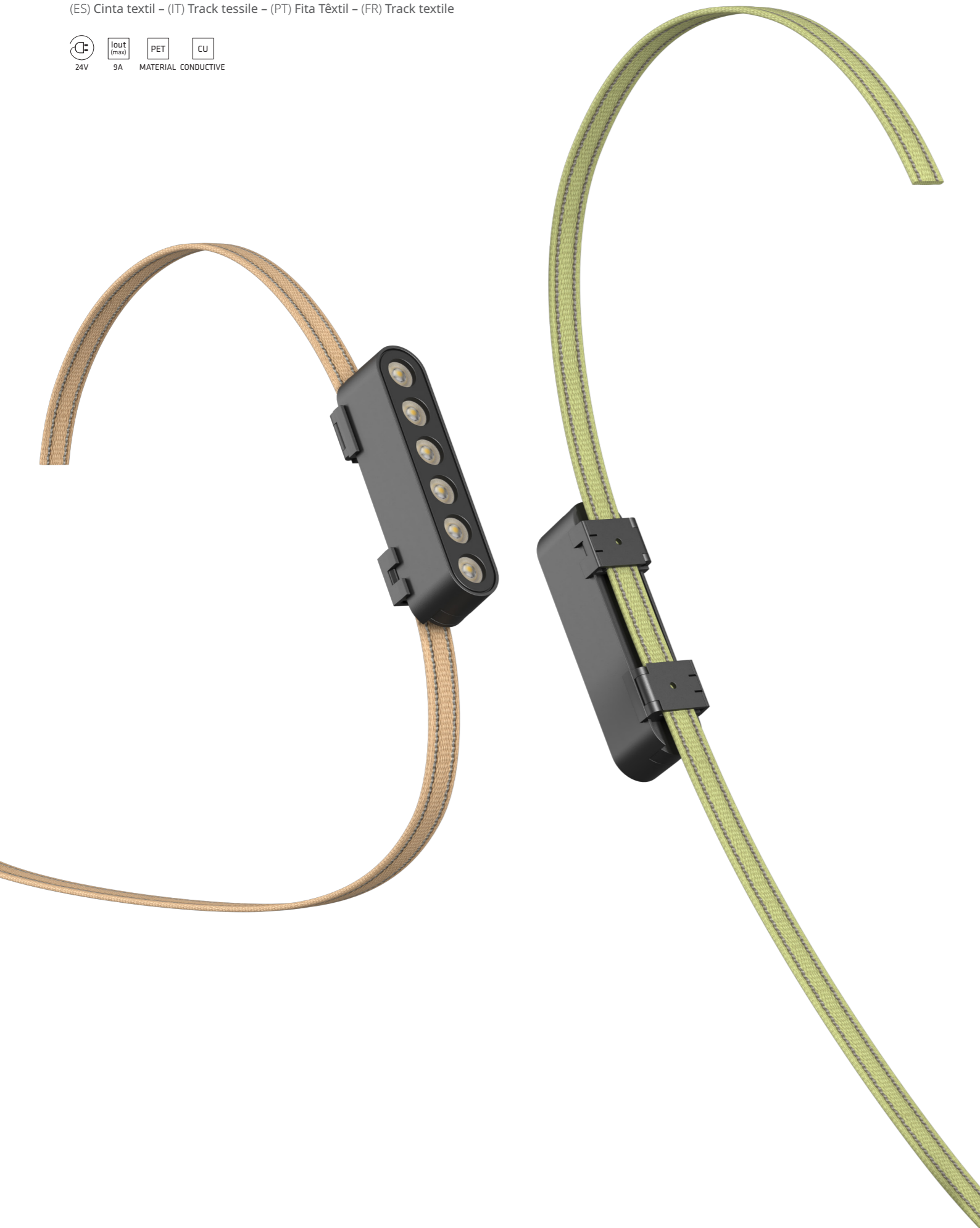

PRO LIMBO Woven track

(ES) Cinta textil - (IT) Track tessile - (PT) Fita têtil - (FR) Track textile







 24V 9A MATERIAL CONDUCTIVE

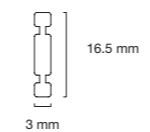

(EN) 6 colors to choose from and mix freely
 (ES) 6 colores a elegir y combinar libremente
 (IT) 6 colori disponibili da scegliere e combinare liberamente
 (PT) 6 cores para seleccionar e misturar livremente
 (FR) 6 couleurs à choisir et à combiner librement



	White	Gray	Black	Green	Khaki	Orange
Custom	24C0CM	24C1CM	24C2CM	24C3CM	24C4CM	24C5CM
10 m	24C0	24C1	24C2	24C3	24C4	24C5
20 m	24C0-20	24C1-20	24C2-20	24C3-20	24C4-20	24C5-20

Connection and fixing large node

(ES) Nodo conexión y fijación grande – (IT) Rosone elettrificato di connessione e fissaggio
(PT) Ponto de conexão e fixação grande – (FR) Nœud de connexion et de fixation grand

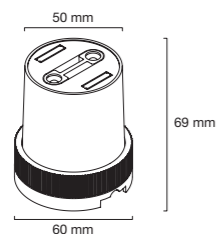

Features:

1. Track conductive conversion function.
2. Braided track steering installation.
3. Suitable for ceiling, wall and ground installation.

(ES) Características:

1. Función de conversión de conductividad del carril.
2. Instalación direccional para la cinta textil.
3. Apto para instalación en techo, pared y suelo.

(IT) Caratteristiche:

1. Funzione di conversione per alimentazione del binario.
2. Installazione direzionale per track tessile.
3. Adatto per installazione a soffitto, parete e pavimento.

(PT) Caracetísticas:

1. Função de conversão de condutância do calha.
2. Instalação da direção para fita têxtil
3. Adequado para instalação no teto, na parede e no chão.

(FR) Caractéristiques :

1. Fonction de conversion de la conductivité du rail.
2. Installation directionnelle du track textile.
3. Convient pour une installation au plafond, mur ou sol.



Woven track input module

(ES) Conector alimentación a cinta textil – (IT) Connettore di alimentazione per track tessile
(PT) Conector de alimentação para fita têxtil – (FR) Connecteur d'alimentation à track textile

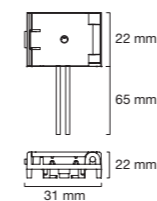
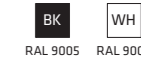

Features:

Braided track power supply module.

(ES) Características:

Módulo de alimentación para la cinta textil.

(IT) Caratteristiche:

Modulo di alimentazione per track tessile.

(PT) Características:

Módulo de alimentação da fita têxtil.

(FR) Caractéristiques:

Module d'alimentation pour le track textile.

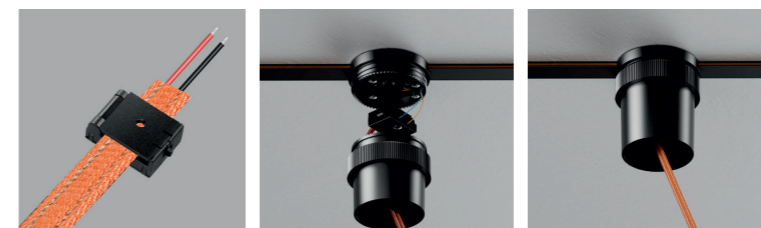

(ES) Opciones de conexión – (IT) Opzioni di collegamento – (PT) Opções de ligação – (FR) Options de connexion

Small fixing node

(ES) Nodo de fijación pequeño – (IT) Accessorio di fissaggio piccolo
(PT) Ponto de fixação pequeno – (FR) Nœud de fixation petit

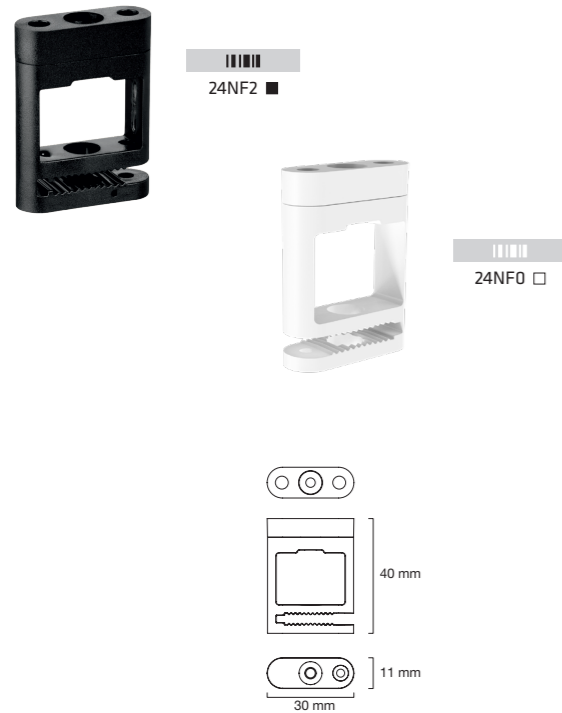
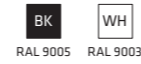

Features:
Woven track holding adjuster bracket.

(ES) Características:
Soporte de sujeción ajustable para la cinta textil.

(IT) Caratteristiche:
Staffa di fissaggio per track tessile.

(PT) Características:
Suporte ajustável de fixação do fita têxtil.

(FR) Caractéristiques:
Support réglable pour le woven track.

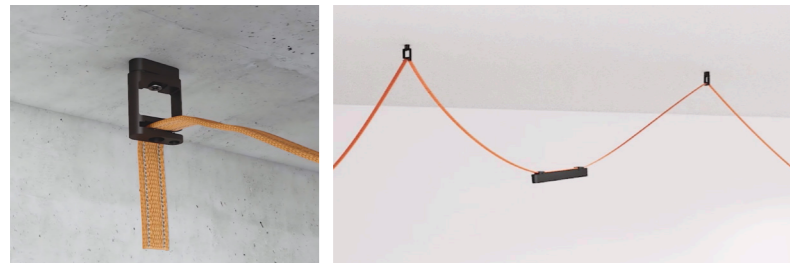

(ES) Opciones de conexión – (IT) Opzioni di collegamento – (PT) Opções de ligação – (FR) Options de connexion

Recessed accessorie for Woven track

(ES) Accesorio de empotrar para cinta textil – (IT) Accessorio incasso per track tessile
(PT) Acessório de encastrar para fita têxtil – (FR) Accessoires encastrés pour track textile



Features:
Woven track holding adjuster bracket.

(ES) Características:
Soporte de sujeción ajustable para la cinta textil.

(IT) Caratteristiche:
Staffa di fissaggio per track tessile.

(PT) Características:
Suporte ajustável de fixação do fita têxtil.

(FR) Caractéristiques:
Support réglable pour le woven track.



(ES) Opciones de conexión - (IT) Opzioni di collegamento - (PT) Opções de ligação - (FR) Options de connexion

Woven track connection clamp

(ES) Pinzas conexión a cinta textil - (IT) Accessorio connessione track tessile
(PT) Pinças de conexão para fita têxtil - (FR) Track textile pince de connexion

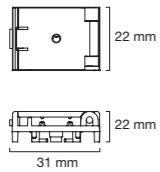
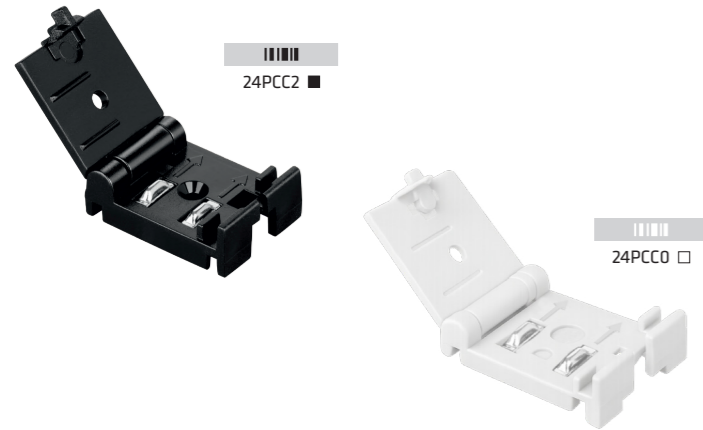

Features:
Clamp to connect light fixtures to the woven track

(ES) Características:
Pinza para conectar luminarias a la cinta textil

(IT) Caratteristiche:
Pinza per connessione al track tessile

(PT) Características:
Pinça para conectar luminárias à fita têxtil

(FR) Caractéristiques:
Pince pour connecter les luminaires au track textile

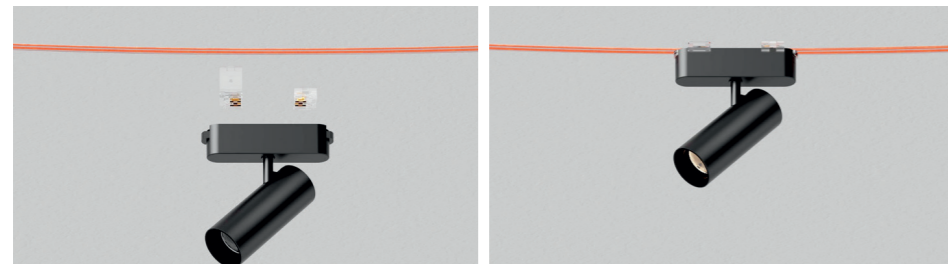

To install the luminaire, 2 units are required

(ES) Para instalar la luminaria se necesitan 2 unidades
(IT) Per installare il corpo illuminante, sono necessari 2 pezzi
(PT) Para instalar a luminária, são necessárias 2 unidades
(FR) Pour installer le luminaire, 2 unités sont nécessaires



(ES) Opciones de conexión - (IT) Opzioni di collegamento - (PT) Opções de ligação - (FR) Options de connexion

Woven track buckle

(ES) Trabilla de sujeción para cinta textil - (IT) Fermaglio fissaggio per track tessile
(PT) Abraçadeira de fixação para fita têxtil - (FR) Clip de fixation pour track textile

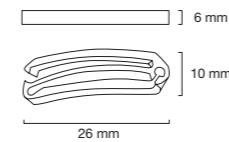

Features:
The woven track can be used to shape at the end.

(ES) Características:
Sirve para ajustar el extremo de la cinta textil.

(IT) Caratteristiche:
Permette di rifinire la parte terminale del track tessile.

(PT) Características:
Permite ajustar a extremidade da fita têxtil

(FR) Caractéristiques:
Le rail tissé peut être utilisé pour modeler les extrémités.

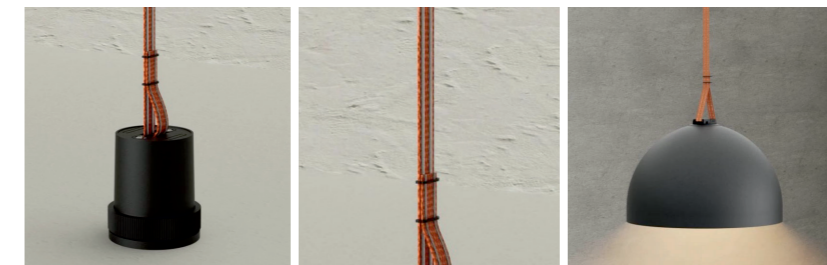

PRO LIMBO 24V Ultra thin linear track

(ES) Carril ultrafino 24V - (IT) Binario lineare ultrasottile 24V
(PT) Calha ultrafino 24V - (FR) Rail ultra-mince 24V

24V 200W MATERIAL AL-CU BK WH RAL 9005 RAL 9003

2m 2m
24SCR2 ■ 24SCR0 □

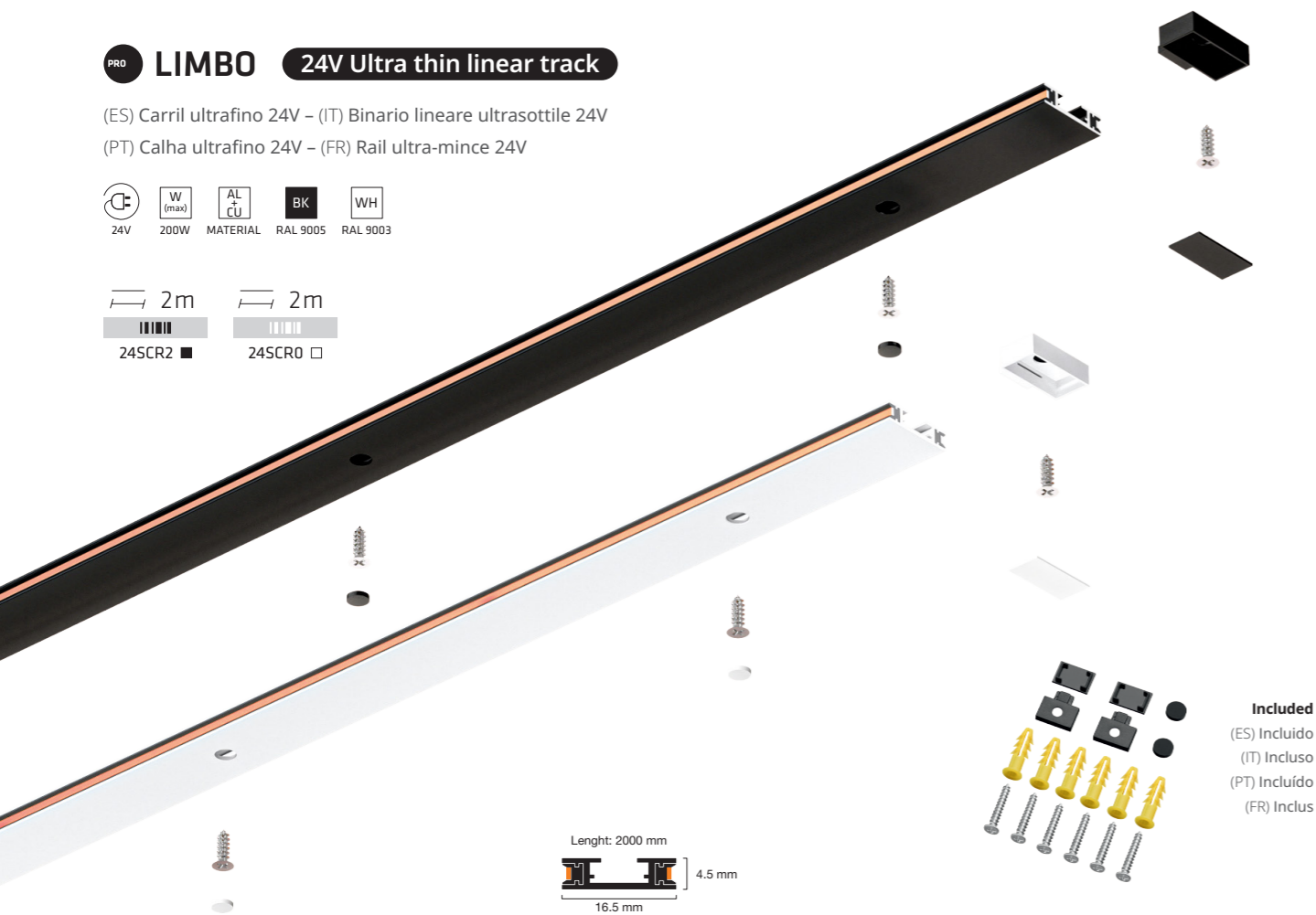

Length: 2000 mm
16.5 mm 4.5 mm
(ES) Longitud: 2000 mm - (IT) Lunghezza: 2000 mm
(PT) Comprimento: 2000 mm - (FR) Longueur: 2000 mm

Included
(ES) Incluido
(IT) Incluso
(PT) Incluído
(FR) Inclus

Track can be cut arbitrarily

(ES) El carril puede cortarse libremente.
(IT) Il binario può essere tagliato liberamente.
(PT) Pode ser cortado livremente.
(FR) Le rail peut être coupé librement.

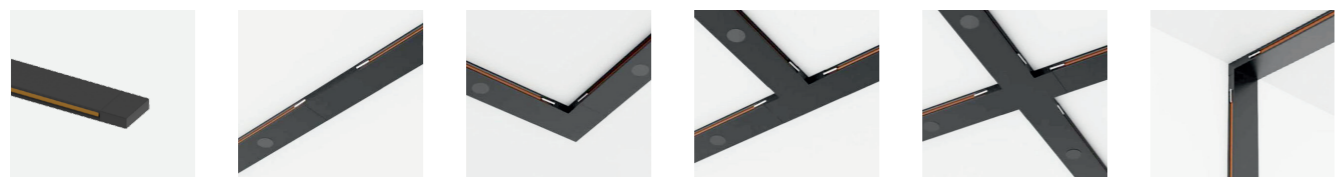
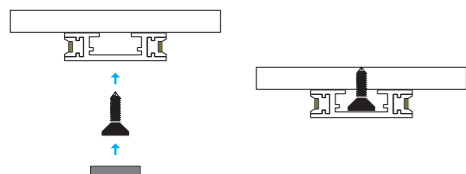

End cover (2 units) (ES) Tapas finales (2 uds.) (IT) Tappi di chiusura (2 pz.) (PT) Tampa final (2 uds.) (FR) Couvercle de fin (2 un.)	Straight connect (ES) Conector recto (IT) Connettore dritto (PT) Conector reto (FR) Connecteur droit	L connect (ES) Conector L (IT) Connettore a L (PT) Conector L (FR) Connecteur L	T connect (ES) Conector T (IT) Connettore a T (PT) Conector T (FR) Connecteur T	Cross connect (ES) Conector X (IT) Connettore a X (PT) Conector X (FR) Connecteur X	90° L connect (ES) Conector L - 90° (IT) Connettore a L - 90° (PT) Conector L - 90° (FR) Connecteur L - 90°
---	---	--	--	--	--

 16.5x16x4.5 mm 24SCRTA2 ■ 24SCRTA0 □	 36.5x16.5x4.5 mm 24SCRT2 ■ 24SCRT0 □	 26.5x26.5x4.5 mm 24SCL2 ■ 24SCL0 □	 36.5x26.5x4.5 mm 24SCT2 ■ 24SCT0 □	 36.5x36.5x4.5 mm 24SCX2 ■ 24SCX0 □	 21.5x21.5x4.5 mm 24SCLP2 ■ 24SCLP0 □
--	--	--	--	--	--

PRO LIMBO 24V Ultra thin linear track

(ES) Carril ultrafino 24V - (IT) Binario lineare ultrasottile 24V
(PT) Calha ultrafino 24V - (FR) Rail ultra-mince 24V

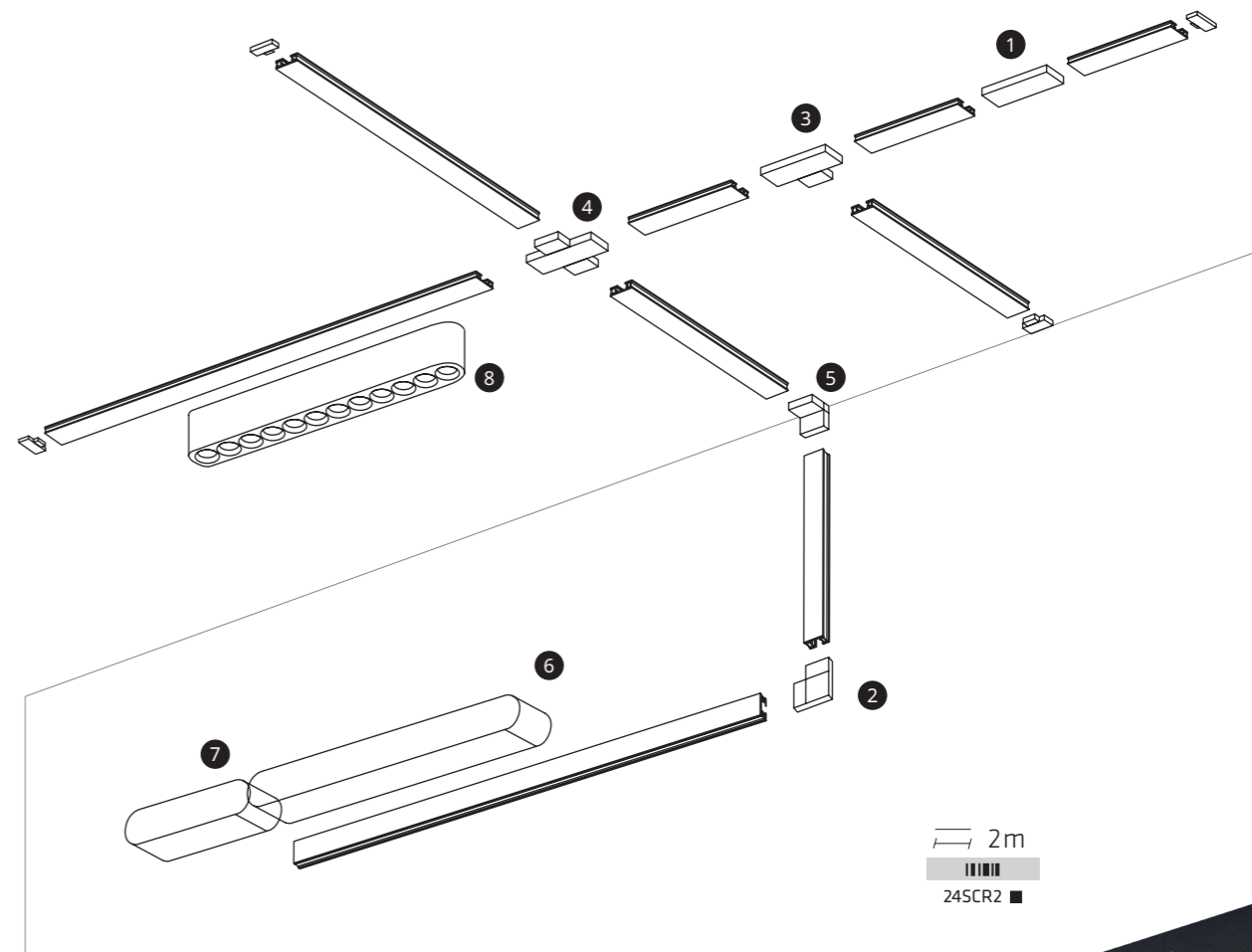

2m
24SCR2 ■



 Ref. 24SCRT2	 Ref. 24SCL2	 Ref. 24SCT2	 Ref. 24SCX2
 Ref. 24SCLP2	 Ref. 24D2002	 Ref. 24ECC2	 Ref. 24LR12CCT2

PRO Linear track accessory

(ES) Accesorio carril 24V - (IT) Accessorio binario lineare 24V
 (PT) Acessório calha ultrafino 24V - (FR) Accessoire rail 24V



Included
 (ES) Incluido
 (IT) Incluso
 (PT) Incluído
 (FR) Inclus

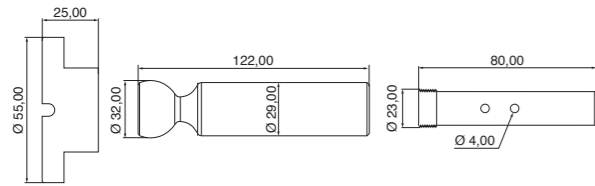

Not Included
 (ES) No incluido
 (IT) Non incluso
 (PT) Não incluído
 (FR) Non inclus



Ref. 24SCR2



Ref. 24CAU2

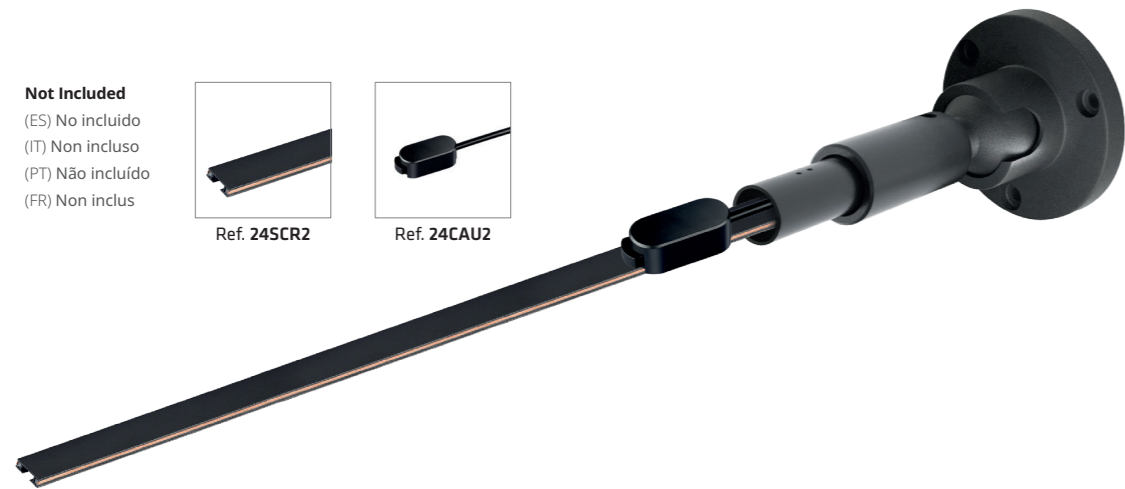

PRO LIMBO 24V Recessed linear track

(ES) Carril de empotrar 24V - (IT) Binario lineare da incasso 24V
 (PT) Calha de encastrar 24V - (FR) Rail encastré 24V

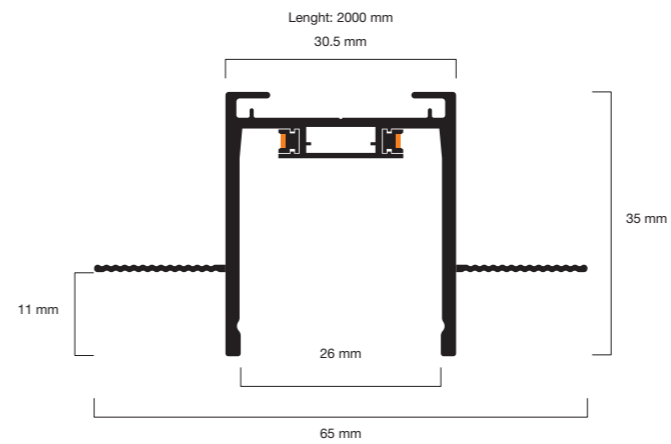
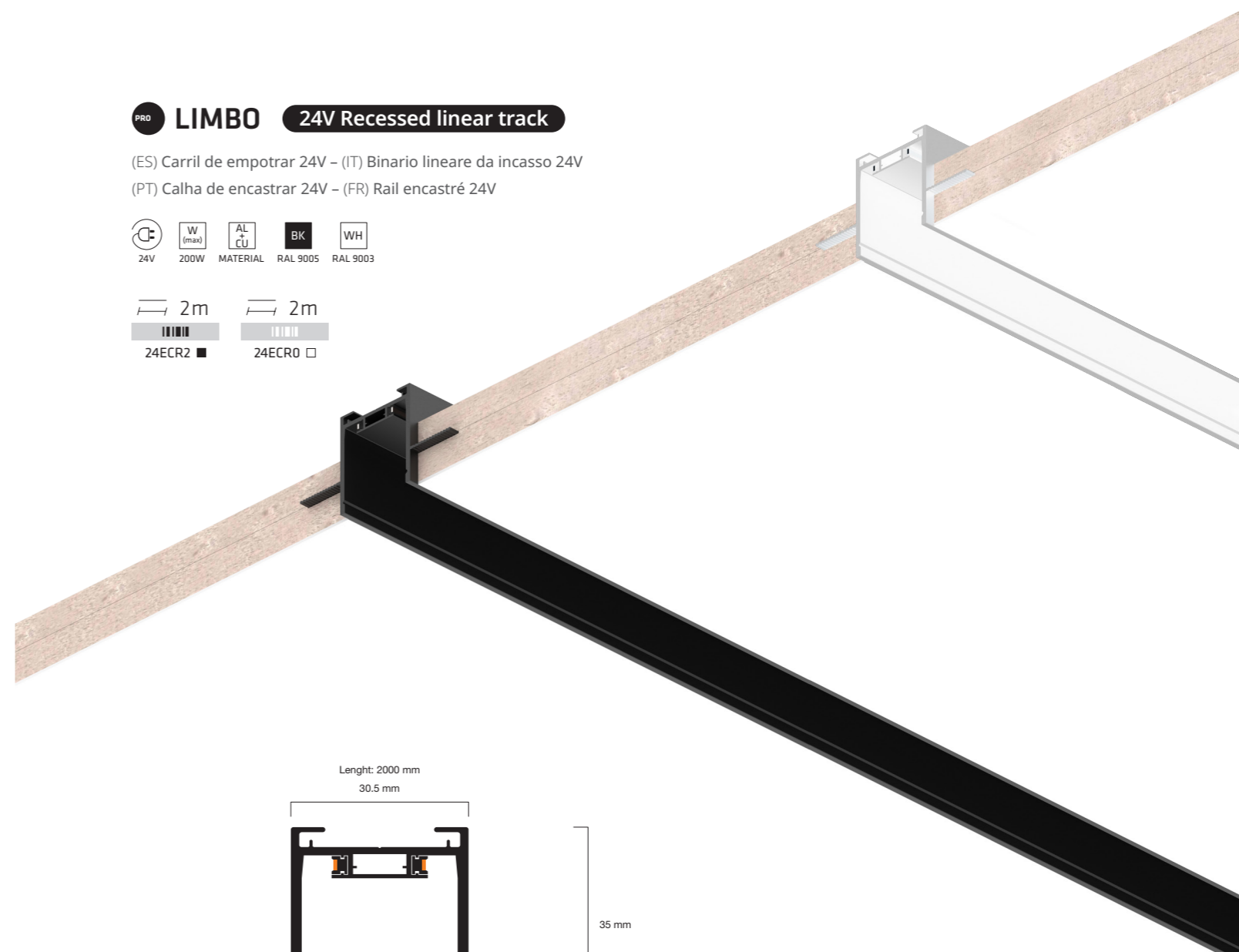
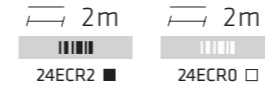

(ES) Longitud: 2000 mm - (IT) Lunghezza: 2000 mm
 (PT) Comprimento: 2000 mm - (FR) Longueur: 2000 mm

Track can be cut arbitrarily

(ES) El carril puede cortarse libremente.
 (IT) Il binario può essere tagliato liberamente.
 (PT) Pode ser cortado livremente.
 (FR) Le rail peut être coupé librement.

- | | | | | | |
|---|---|---|--|--|---|
| <p>Recessed linear track
 (ES) Carril de empotrar
 (IT) Binario lineare da incasso
 (PT) Carril de encastrar
 (FR) Rail encastré</p> | <p>Recessed track cover
 (ES) Cobertor para carril
 (IT) Copertura per binario
 (PT) Tampa para calha
 (FR) Couverture pour rail</p> | <p>Recessed track end cover
 (ES) Tapas finales (2 uds.)
 (IT) Tappo per binario (2 pz.)
 (PT) Tampa final (2 uds.)
 (FR) Couverture de fin (2 uds.)</p> | <p>L-splice
 (ES) Junta en L
 (IT) Giunto a L
 (PT) União em L
 (FR) Joint en L</p> | <p>90° L Coupling piece
 (ES) Junta en L - 90°
 (IT) Giunto a L - 90°
 (PT) União em L - 90°
 (FR) Joint en L - 90°</p> | <p>Power module
 (ES) Módulo alimentación
 (IT) Connettore alimentazione
 (PT) Módulo de alimentação
 (FR) Module d'alimentation</p> |
|---|---|---|--|--|---|



24ECR2 ■
24ECR0 □



24ECRC2 ■
24ECRC0 □



24ECRTA2 ■
24ECRTA0 □



24ECL2 ■
24ECL0 □



24ECLP2 ■
24ECLP0 □



24CAB2 ■
24CAB0 □

(ES) Fuentes de alimentación - (IT) Alimentazione - (PT) Fontes de alimentação - (FR) Alimentation

ON-OFF Power supply 100W

(ES) Fuente de alimentación 100W - (IT) Driver 100W - (PT) Fonte de alimentação 100W - (FR) Alimentation 100W

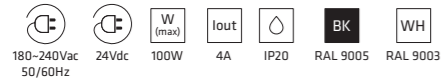

24D1002 ■

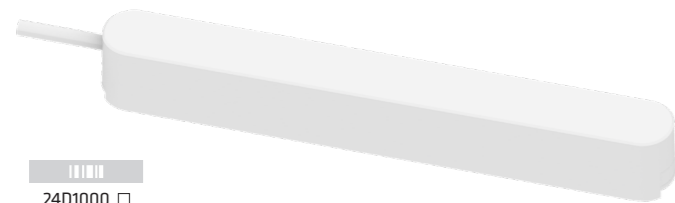

24D1000 □

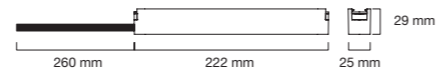

ON-OFF Power supply 200W

(ES) Fuente de alimentación 200W - (IT) Driver 200W - (PT) Fonte de alimentação 200W - (FR) Alimentation 200W

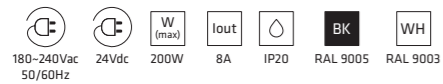

24D2002 ■

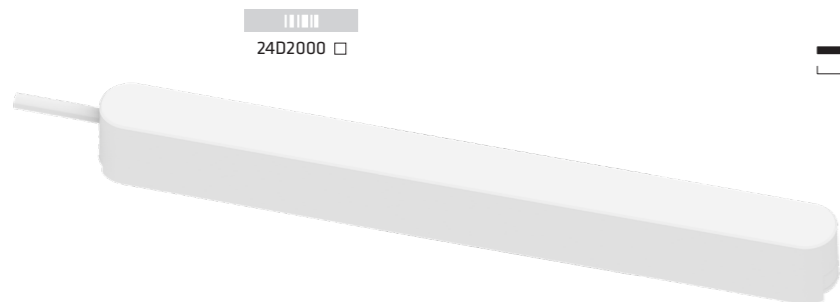

24D2000 □

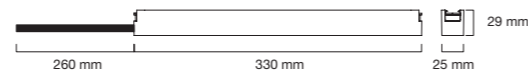

(ES) Fuentes de alimentación - (IT) Alimentazione - (PT) Fontes de alimentação - (FR) Alimentation

Cable box

(ES) Embellecedor cubre cables - (IT) Accessorio copri fili - (PT) Embelezador para cobertura de cabos - (FR) Cache-câble

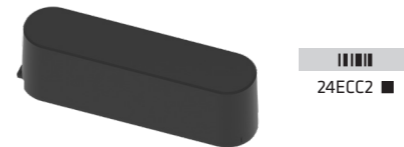
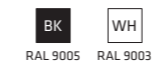

24ECC2 ■



24ECC0 □

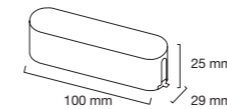

Features:

Hide the power input cable.

(ES) Características:
Oculta el cable de entrada de alimentación.

(IT) Caratteristiche:
Nasconde il cavo di ingresso dell'alimentazione.

(PT) Características:
Esconde o cabo de entrada de alimentação.

(FR) Caractéristiques:
Cacher le câble d'entrée d'alimentation.

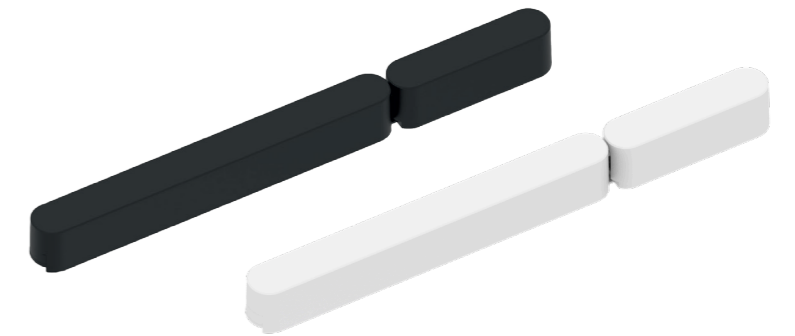

The power supply is installed at the end of the track.

(ES) La fuente de alimentación se instala al final del carril - (IT) L'alimentazione può essere installata all'estremità del binario - (PT) Fonte de alimentação instalada no final do calha - (FR) L'alimentation est installée à l'extrémité du rail

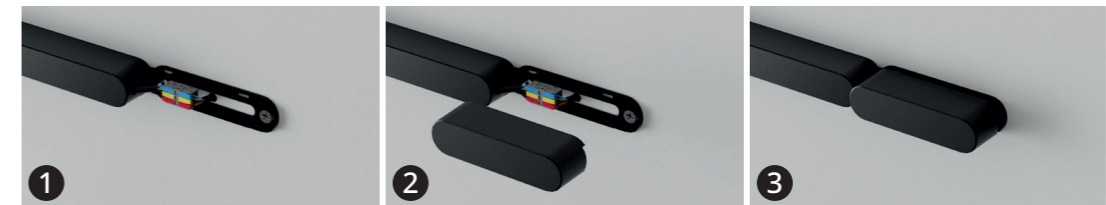

Power supply mounted anywhere on the track.

(ES) La fuente de alimentación puede instalarse en cualquier parte del carril - (IT) L'alimentazione può essere installata ovunque sul binario - (PT) Fonte de alimentação montada em qualquer parte do calha - (FR) Alimentation pouvant être montée n'importe où sur le rail.

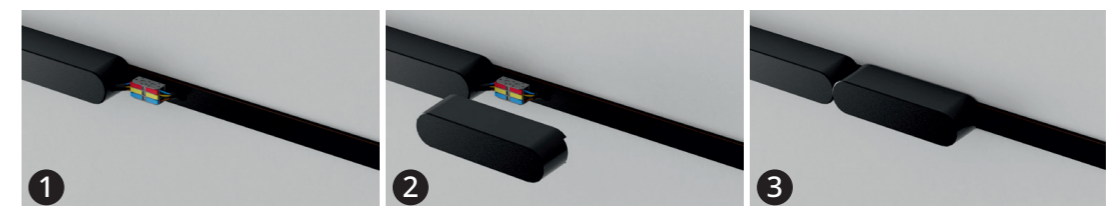

PRO **LIMBO** Input module

(ES) Conector alimentación unidireccional – (IT) Connett. alimentazione unidirezionale
 (PT) Conector de alimentação unidireccional – (FR) Connecteur d'alimentation unidirectionnel

BK WH
 RAL 9005 RAL 9003

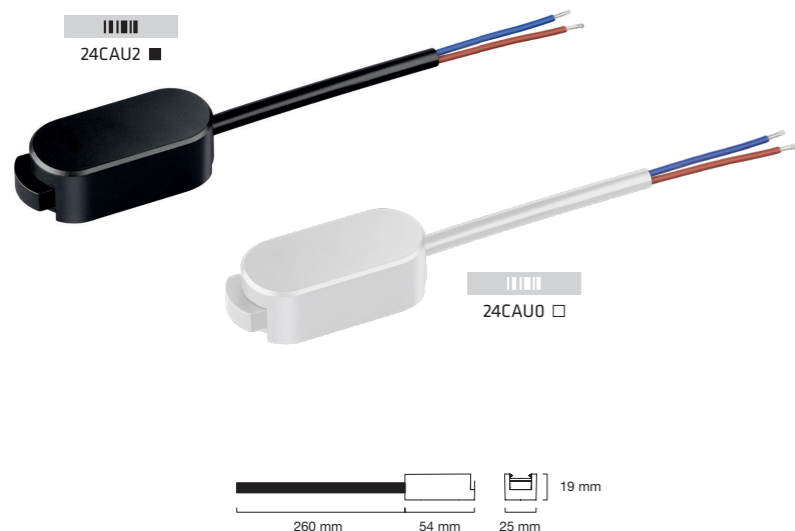

Features:
 The track bar is energized by connecting the input module with an external transformer.

(ES) Características:
 El carril se electrifica conectando el módulo de entrada con un transformador externo.

(IT) Caratteristiche:
 Il binario viene alimentato collegando il connettore di alimentazione a un driver esterno.

(PT) Características:
 O calha é ligado conectando o módulo de entrada a um transformador externo.

(FR) Caractéristiques:
 La barre de rail est alimentée en connectant le module d'entrée avec un transformateur externe.

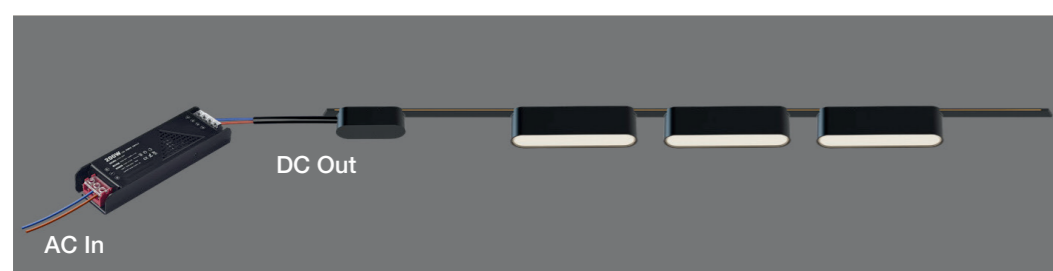

PRO **LIMBO** Direct power module / Angle power module

(ES) Módulo de alimentación directa / Módulo de alimentación flexible – (IT) Connettore di alimentazione bidirezionale diretta / angolare
 (PT) Módulo de alimentação direta / Módulo de alimentação angular – (FR) Module d'alimentation direct / Module d'alimentation d'angle

BK WH
 RAL 9005 RAL 9003

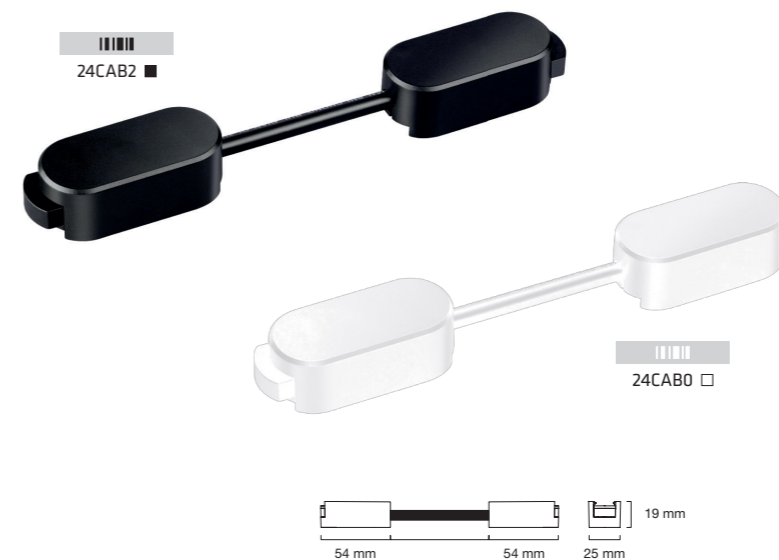

Features:
 The power module is used to energize the rails when they are joined.
 Two unconnected rails can be connected with electricity.
 The connection can be straight line or angled.

(ES) Características:
 El módulo de alimentación proporciona energía a los carriles cuando se unen. Permite electrificar dos raíles inicialmente desconectados. La conexión se puede realizar en línea recta y en ángulo (esquina).

(IT) Caratteristiche:
 Il connettore bidirezionale si utilizza per alimentare binari collegati. Due binari non collegati possono essere uniti elettricamente. La connessione può essere realizzata in linea retta o ad angolo.

(PT) Características:
 O módulo de alimentação é usado para ligar os calhas quando são conectados. Permite eletrificar dois carris inicialmente desconectados. Compatível com ligações em linha reta e em ângulo (canto).

(FR) Caractéristiques:
 Le module d'alimentation est utilisé pour alimenter les rails lorsqu'ils sont reliés. Il permet d'électrifier deux rails initialement non connectés. Connexion possible en ligne droite ou en coin.



PRO LIMBO Cone luminaire

(ES) Luminaria cono - (IT) Lampada cono
(PT) Luminária cone - (FR) Luminaire à cône



PRO LIMBO Semi sphere luminaire

(ES) Luminaria semi esfera - (IT) Lampada semisfera
(PT) Luminária semi-esfera - (FR) Luminaire semi-sphérique

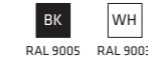

24C18
18W

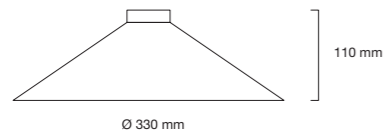

Version	CCT	Lm
24C18C9302 ■	24C18C9300 □	Version CRI>90
		● 3000 K 993 Lm



Can only be installed on Woven track

(ES) Solo se puede instalar en la cinta textil - (IT) Può essere installato solo sul track tessile
(PT) Só pode ser instalado no fita têxtil - (FR) Ne peut être installé que sur le track textile

24SE18
18W

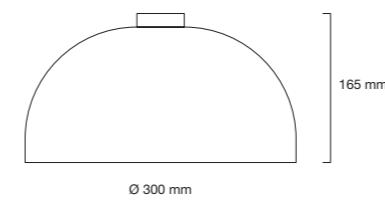

Version	CCT	Lm
24SE18C9302 ■	24SE18C9300 □	Version CRI>90
		● 3000 K 780 Lm



Can only be installed on Woven track

(ES) Solo se puede instalar en la cinta textil - (IT) Può essere installato solo sul track tessile
(PT) Só pode ser instalado no fita têxtil - (FR) Ne peut être installé que sur le track textile

PRO LIMBO **Globe luminaire**

(ES) Luminaria globo - (IT) Lampada globo
(PT) Luminária globo - (FR) Luminaire globe

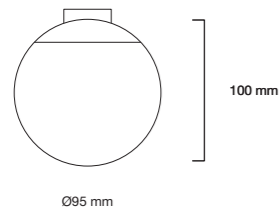

24G6
6W

Version	CCT	Lm		
24G6C9302 ■	24G6C9300 □	Version	CCT	Lm
24G6C9302 ■	24G6C9300 □	● CRI>90	● 3000 K	249 Lm

Can only be installed on Woven track

(ES) Solo se puede instalar en la cinta textil - (IT) Può essere installato solo sul track tessile
(PT) Só pode ser instalado no fita têxtil - (FR) Ne peut être installé que sur le track textile

PRO LIMBO **Luminaires versions**

(ES) Versiones de las luminarias - (IT) Versioni di lampade - (PT) Versões das luminárias - (FR) Versions des luminaires

There are two systems for lighting fixtures option according to your needs

(ES) Disponemos de dos sistemas de luminarias según sus necesidades - (IT) Ci sono due tipi di corpi illuminanti disponibili in base alle tue esigenze
(PT) Existem dois sistemas de luminárias disponíveis de acordo com as suas necessidades - (FR) Deux systèmes de luminaires sont disponibles selon les besoins de votre projet

Version 1

CRI>90

Regular monochrome version

(ES) Versión monocolor estándar
(IT) Versione monocromatica standard
(PT) Versão monocromática regular
(FR) Version monochrome standard



Version 1	CCT
● CRI>90	● 2700 K
	● 3000 K
	● 4000 K

Version 2

CCT SWITCH

Switchable light colors version

(ES) Versión con tonalidades de luz conmutables
(IT) Versione con CCT Switch
(PT) Versão de cores de luz comutáveis
(FR) Version avec couleurs de lumière commutables



Version 2	CCT
● CCT SWITCH	● 3000 K
	● 4000 K
	● 6000 K

With conventional power supply switchable for 3 CCT

(ES) Alimentación convencional conmutable para 3 CCT
(IT) Con alimentazione standard e CCT Switch per le tre tonalità
(PT) Com fonte de alimentação convencional comutável para 3 CCT
(FR) Avec une alimentation conventionnelle commutable entre 3 CCT

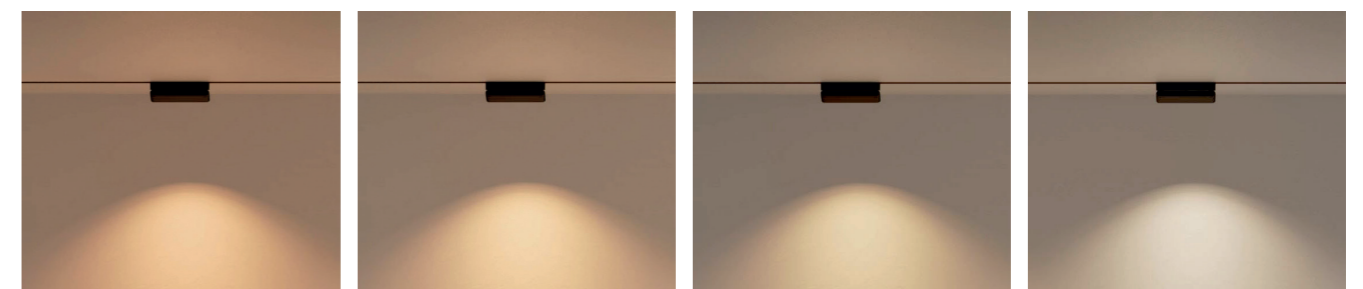

PRO **LIMBO** Linear light

(ES) Luminaria Lineal - (IT) Luce lineare
(PT) Luminária linear - (FR) Luminaire linéaire

Version 1 Version 2



CRI > 90

CCT SWITCH



BK WH
RAL 9005 RAL 9003



24L6
6W

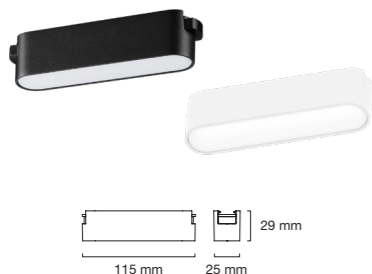

ITEM	ITEM	Version	CCT	Lm
24L6C9272	24L6C9270	CRI > 90	2700 K	202 Lm
24L6C9302	24L6C9300		3000 K	207 Lm
24L6C9402	24L6C9400		4000 K	209 Lm
24L6CCT2	24L6CCT0	CCT SWITCH	3000 K 4000 K 6000 K	207 Lm 209 Lm 217 Lm

PRO **LIMBO** Linear grille light

(ES) Luminaria lineal rejilla - (IT) Luce lineare fori
(PT) Luminária linear de grelha - (FR) Luminaire linéaire à grille

Version 1 Version 2



CRI > 90

CCT SWITCH



BK WH
RAL 9005 RAL 9003



24LR6
6W

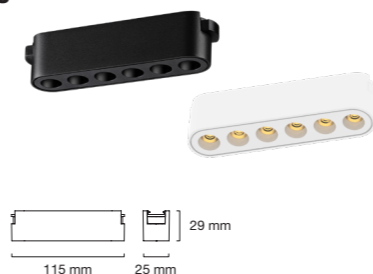

ITEM	ITEM	Version	CCT	Lm
24LR6C9272	24LR6C9270	CRI > 90	2700 K	204 Lm
24LR6C9302	24LR6C9300		3000 K	237 Lm
24LR6C9402	24LR6C9400		4000 K	241 Lm
24LR6CCT2	24LR6CCT0	CCT SWITCH	3000 K 4000 K 6000 K	237 Lm 241 Lm 253 Lm

24L12
12W

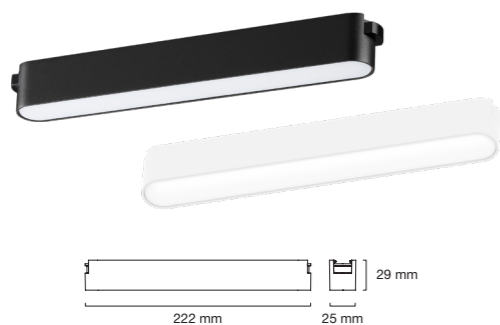

ITEM	ITEM	Version	CCT	Lm
24L12C9272	24L12C9270	CRI > 90	2700 K	417 Lm
24L12C9302	24L12C9300		3000 K	429 Lm
24L12C9402	24L12C9400		4000 K	440 Lm
24L12CCT2	24L12CCT0	CCT SWITCH	3000 K 4000 K 6000 K	429 Lm 440 Lm 470 Lm

24LR12
12W

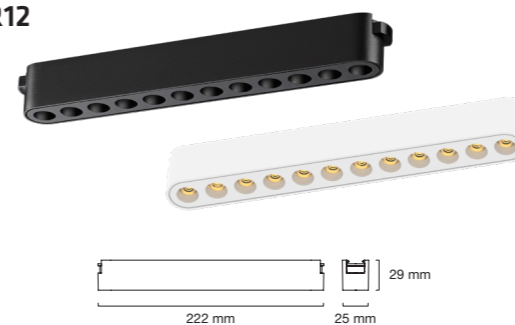

ITEM	ITEM	Version	CCT	Lm
24LR12C9272	24LR12C9270	CRI > 90	2700 K	480 Lm
24LR12C9302	24LR12C9300		3000 K	482 Lm
24LR12C9402	24LR12C9400		4000 K	489 Lm
24LR12CCT2	24LR12CCT0	CCT SWITCH	3000 K 4000 K 6000 K	482 Lm 489 Lm 515 Lm

24L18
18W

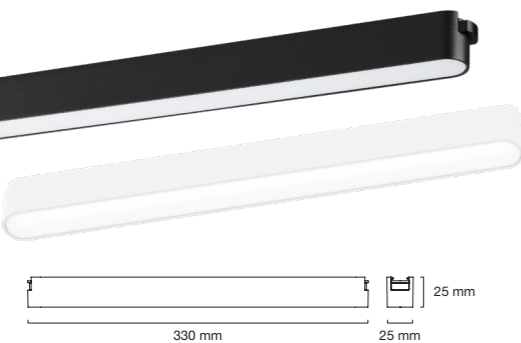

ITEM	ITEM	Version	CCT	Lm
24L18C9272	24L18C9270	CRI > 90	2700 K	620 Lm
24L18C9302	24L18C9300		3000 K	622 Lm
24L18C9402	24L18C9400		4000 K	639 Lm
24L18CCT2	24L18CCT0	CCT SWITCH	3000 K 4000 K 6000 K	622 Lm 639 Lm 684 Lm

24LR18
18W

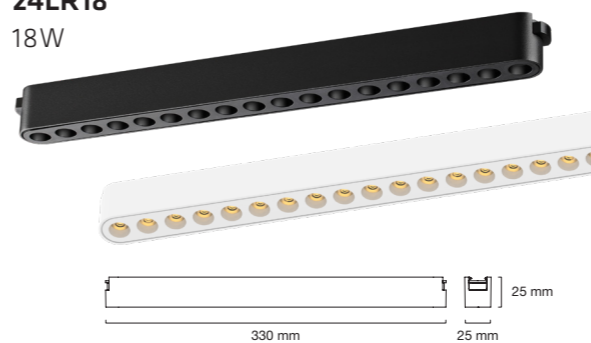

ITEM	ITEM	Version	CCT	Lm
24LR18C9272	24LR18C9270	CRI > 90	2700 K	698 Lm
24LR18C9302	24LR18C9300		3000 K	700 Lm
24LR18C9402	24LR18C9400		4000 K	710 Lm
24LR18CCT2	24LR18CCT0	CCT SWITCH	3000 K 4000 K 6000 K	700 Lm 710 Lm 750 Lm

PRO **LIMBO** Linear folding light

(ES) Luminaria lineal orientable - (IT) Luce lineare orientabile
(PT) Luminária linear orientável - (FR) Luminaire linéaire orientable



Rotable direction



2406
6W

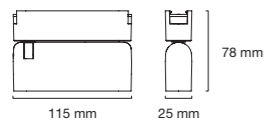

Version	CCT	Lm
CRI>90	2700 K	210 Lm
	3000 K	212 Lm
	4000 K	219 Lm
CCT SWITCH	3000 K	212 Lm
	4000 K	219 Lm
	6000 K	234 Lm

PRO **LIMBO** Linear folding grille light

(ES) Luminaria lineal orientable rejilla - (IT) Luce lineare orientabile fori
(PT) Luminária linear orientável de grelha - (FR) Luminaire linéaire à grille réglable

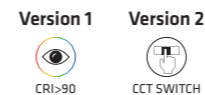

Rotable direction



240R6
6W

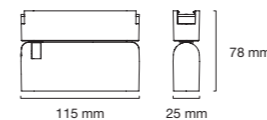

Version	CCT	Lm
CRI>90	2700 K	204 Lm
	3000 K	237 Lm
	4000 K	241 Lm
CCT SWITCH	3000 K	237 Lm
	4000 K	241 Lm
	6000 K	253 Lm

24012
12W

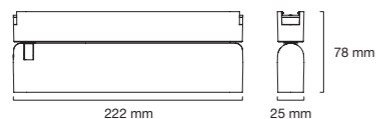

Version	CCT	Lm
CRI>90	2700 K	427 Lm
	3000 K	429 Lm
	4000 K	440 Lm
CCT SWITCH	3000 K	429 Lm
	4000 K	440 Lm
	6000 K	470 Lm

240R12
12W

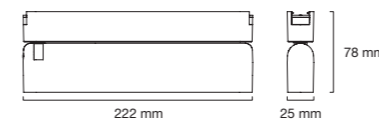

Version	CCT	Lm
CRI>90	2700 K	480 Lm
	3000 K	482 Lm
	4000 K	489 Lm
CCT SWITCH	3000 K	482 Lm
	4000 K	489 Lm
	6000 K	515 Lm

24018
18W



Version	CCT	Lm
CRI>90	2700 K	620 Lm
	3000 K	622 Lm
	4000 K	639 Lm
CCT SWITCH	3000 K	622 Lm
	4000 K	639 Lm
	6000 K	684 Lm

240R18
18W

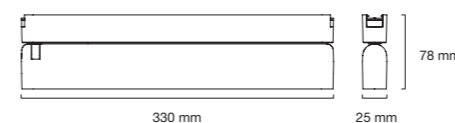

Version	CCT	Lm
CRI>90	2700 K	689 Lm
	3000 K	700 Lm
	4000 K	710 Lm
CCT SWITCH	3000 K	700 Lm
	4000 K	710 Lm
	6000 K	750 Lm

PRO LIMBO Triple grille spotlight

(ES) Triple foco de rejilla - (IT) Faretto triplo
(PT) Foco triplo de grelha - (FR) Spot triple

Version 1 Version 2



CRI > 90



CCT SWITCH

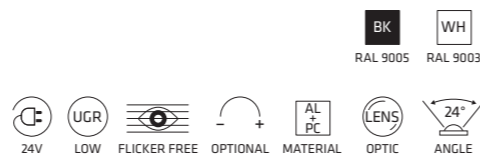

243R6
6W

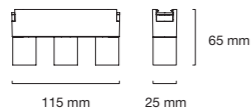

ITEM	ITEM	Version	CCT	Lm
243R6C9272	243R6C9270	CRI > 90	2700 K	240 Lm
243R6C9302	243R6C9300		3000 K	279 Lm
243R6C9402	243R6C9400		4000 K	285 Lm
243R6CCT2	243R6CCT0	CCT SWITCH	3000 K	279 Lm
			4000 K	285 Lm
			6000 K	297 Lm

PRO LIMBO Surface mounted spotlight

(ES) Foco superficie - (IT) Faretto superficie
(PT) Foco de superfície - (FR) Spot surface

Version 1 Version 2



CRI > 90



CCT SWITCH

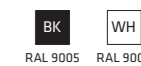

24FS6
6W

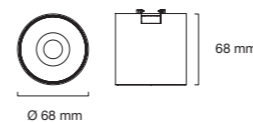

ITEM	ITEM	Version	CCT	Lm
24FS6C9272	24FS6C9270	CRI > 90	2700 K	317 Lm
24FS6C9302	24FS6C9300		3000 K	325 Lm
24FS6C9402	24FS6C9400		4000 K	334 Lm
24FS6CCT2	24FS6CCT0	CCT SWITCH	3000 K	325 Lm
			4000 K	334 Lm
			6000 K	362 Lm

PRO **LIMBO** Adjustable tracklight

(ES) Foco tracklight orientable - (IT) Tracklight orientabile
(PT) Foco orientável para carril - (FR) Spot sur rail orientable

Version 1 Version 2



BK WH
RAL 9005 RAL 9003



241X6
6W



Version	CCT	Lm
CRI > 90	2700 K	243 Lm
	3000 K	249 Lm
	4000 K	264 Lm
CCT SWITCH	3000 K	249 Lm
	4000 K	264 Lm
	6000 K	293 Lm

PRO **LIMBO** Adjustable double tracklight

(ES) Doble tracklight orientable - (IT) Doppio tracklight orientabile
(PT) Foco duplo orientável - (FR) Spot sur rail double direction

Version 1 Version 2

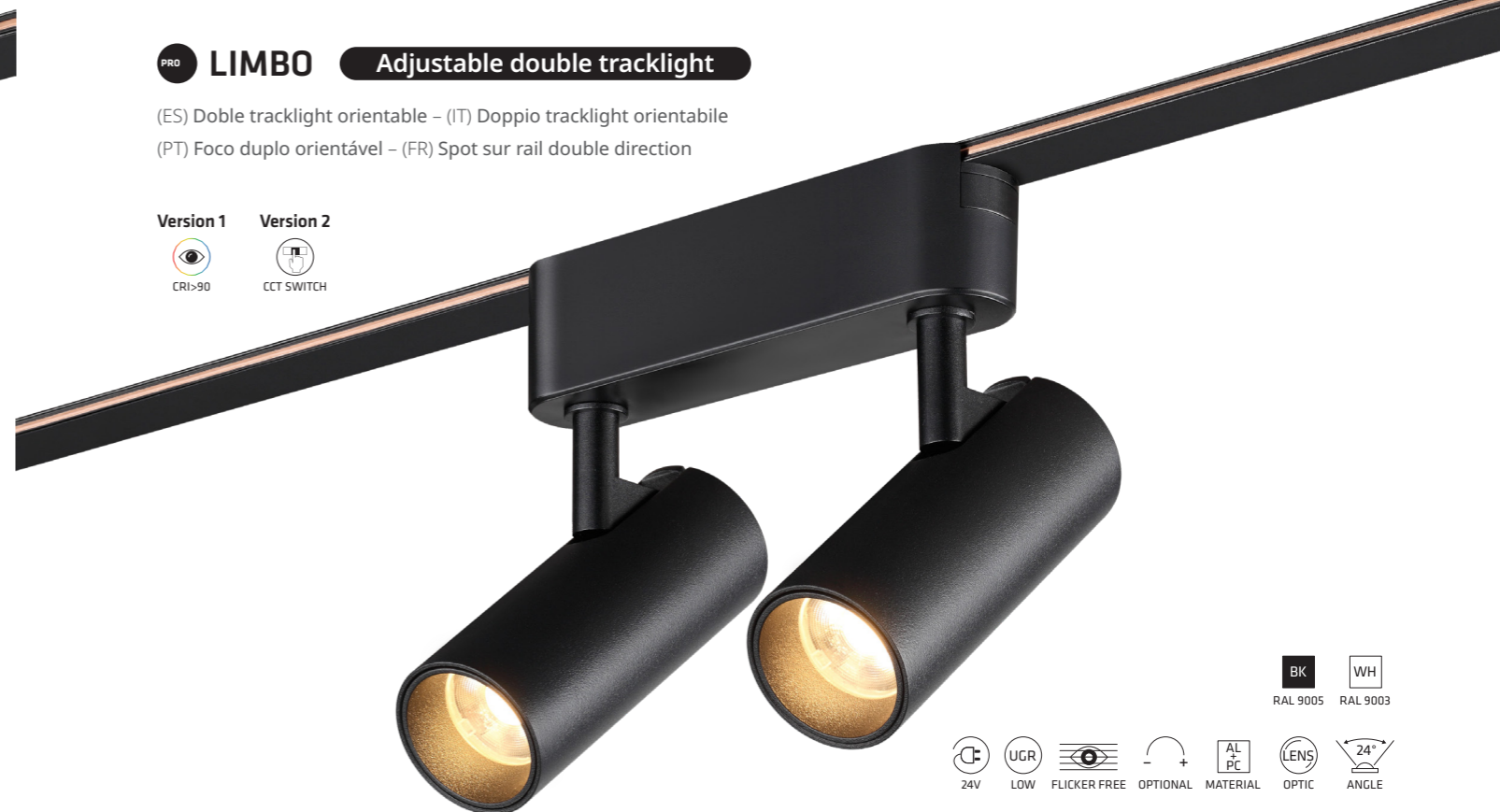

BK WH
RAL 9005 RAL 9003



242X6
6Wx2

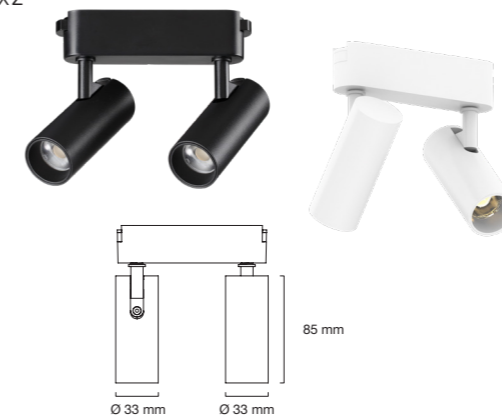

Version	CCT	Lm
CRI > 90	2700 K	530 Lm
	3000 K	542 Lm
	4000 K	548 Lm
CCT SWITCH	3000 K	542 Lm
	4000 K	548 Lm
	6000 K	608 Lm

241X12
12W



Version	CCT	Lm
CRI > 90	2700 K	512 Lm
	3000 K	516 Lm
	4000 K	520 Lm
CCT SWITCH	3000 K	516 Lm
	4000 K	520 Lm
	6000 K	556 Lm

242X12
12Wx2



Version	CCT	Lm
CRI > 90	2700 K	1272 Lm
	3000 K	1275 Lm
	4000 K	1285 Lm
CCT SWITCH	3000 K	1275 Lm
	4000 K	1285 Lm
	6000 K	1424 Lm

PRO **LIMBO** Sphere lumineaire

(ES) Luminaria esfera - (IT) Lampada sfera
(PT) Luminária esfera - (FR) Luminaire sphérique

Version 1 Version 2



CRI > 90



CCT SWITCH



BK WH
RAL 9005 RAL 9003



24E6C9

6W

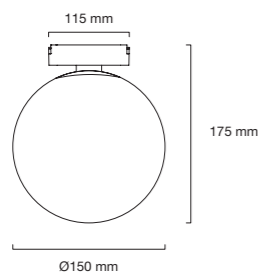

ITEM	ITEM	Version	CCT	Lm
24E6C9272	24E6C9270	CRI > 90	2700 K	338 Lm
24E6C9302	24E6C9300		3000 K	341 Lm
24E6C9402	24E6C9400		4000 K	344 Lm
24E6CCT2	24E6CCT0	CCT SWITCH	3000 K 4000 K 6000 K	341 Lm 344 Lm 389 Lm

PRO **LIMBO** Wall washer lamp

(ES) Bañador Pared - (IT) Wallwasher
(PT) Aplique de parede - (FR) Lèche-mur

Version 1 Version 2



CRI > 90



CCT SWITCH



BK WH
RAL 9005 RAL 9003



24BP9

9W

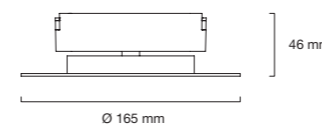

ITEM	ITEM	Version	CCT	Lm
24BP9C9272	24BP9C9270	CRI > 90	2700 K	25 Lm
24BP9C9302	24BP9C9300		3000 K	26 Lm
24BP9C9402	24BP9C9400		4000 K	27 Lm
24BP9CCT2	24BP9CCT0	CCT SWITCH	3000 K 4000 K 6000 K	26 Lm 27 Lm 28 Lm

PRO **LIMBO** Cone luminaire

(ES) Luminaria cono - (IT) Lampada cono
(PT) Luminária Cone - (FR) Luminaire à cône

Version 1 Version 2



CRI > 90



CCT SWITCH



24C6C9
6W

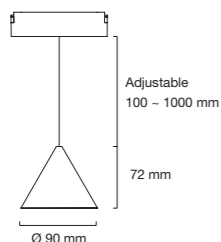

Item	Item	Version	CCT	Lm
24C6C9272	24C6C9270	CRI > 90	2700 K	205 Lm
24C6C9302	24C6C9300		3000 K	209 Lm
24C6C9402	24C6C9400		4000 K	239 Lm
24C6CCT2	24C6CCT0	CCT SWITCH	3000 K	209 Lm
			4000 K	239 Lm
			6000 K	275 Lm

PRO **LIMBO** Silicon light

(ES) Silicon light - (IT) Silicon light
(PT) Luz de silicone - (FR) Luminaire silicone

Version 1 Version 2



CRI > 90



CCT SWITCH



24S14
14W



24S28
28W

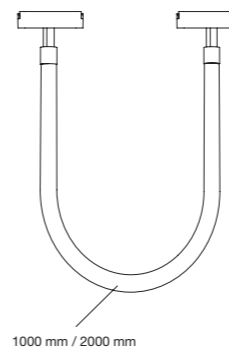

U_{1m}

Item	Item	Version	CCT	Lm
24S14C9272	24S14C9270	CRI > 90	2700 K	665 Lm
24S14C9302	24S14C9300		3000 K	672 Lm
24S14C9402	24S14C9400		4000 K	952 Lm
24S14CCT2	24S14CCT0	CCT SWITCH	3000 K	672 Lm
			4000 K	952 Lm
			6000 K	965 Lm

U_{2m}

Item	Item	Version	CCT	Lm
24S28C9272	24S28C9270	CRI > 90	2700 K	1300 Lm
24S28C9302	24S28C9300		3000 K	1344 Lm
24S28C9402	24S28C9400		4000 K	1904 Lm
24S28CCT2	24S28CCT0	CCT SWITCH	3000 K	1344 Lm
			4000 K	1904 Lm
			6000 K	1930 Lm

PRO LIMBO Control options

(ES) Opciones de control - (IT) Opzioni di controllo - (PT) Opções de controlo - (FR) Options de contrôle

Non-dimming power supply combined with a controller

(ES) Fuente de alimentación no regulable combinada con un controlador - (IT) Alimentatore non dimmerabile combinato con un controller - (PT) Fonte de alimentação não regulável combinada com um controlador - (FR) Alimentation non dimmable combinée à un contrôleur



PRO LIMBO Control options

(ES) Opciones de control - (IT) Opzioni di controllo - (PT) Opções de controlo - (FR) Options de contrôle

Wiring diagram for dimming power supply

(ES) Esquema de conexión para fuente de alimentación - (IT) Schema di collegamento per alimentatore dimmerabile - (PT) Diagrama de ligação para fonte de alimentação dimável - (FR) Schéma de câblage pour alimentation dimmable

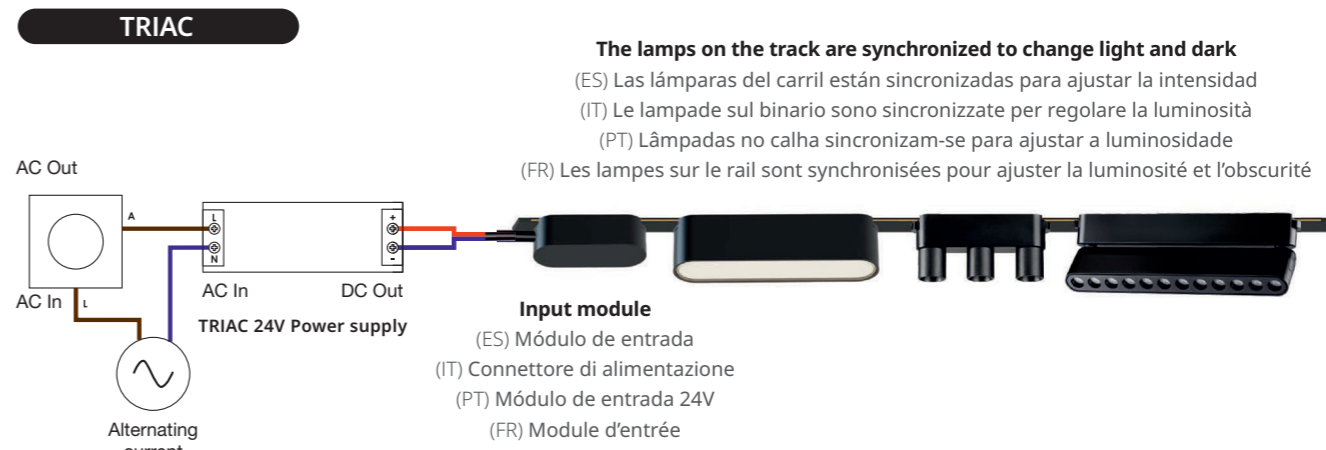

DALI 0-10V

Both are wired in the same way
(ES) Ambos sistemas se cablean de la misma manera - (IT) Entrambi cablati nello stesso modo - (PT) Ambos são ligados da mesma forma - (FR) Les deux sont câblés de la même manière

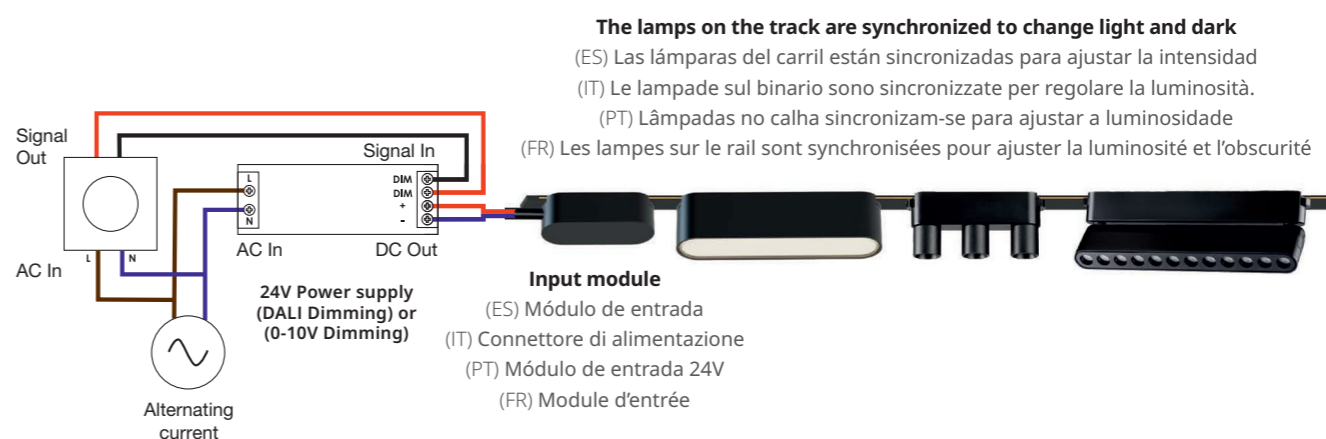

PRO LIMBO Woven track installation

(ES) Instalación con la cinta textil - (IT) Installazione con il track tessile - (PT) Instalação com fita têxtil - (FR) Pose avec track textile

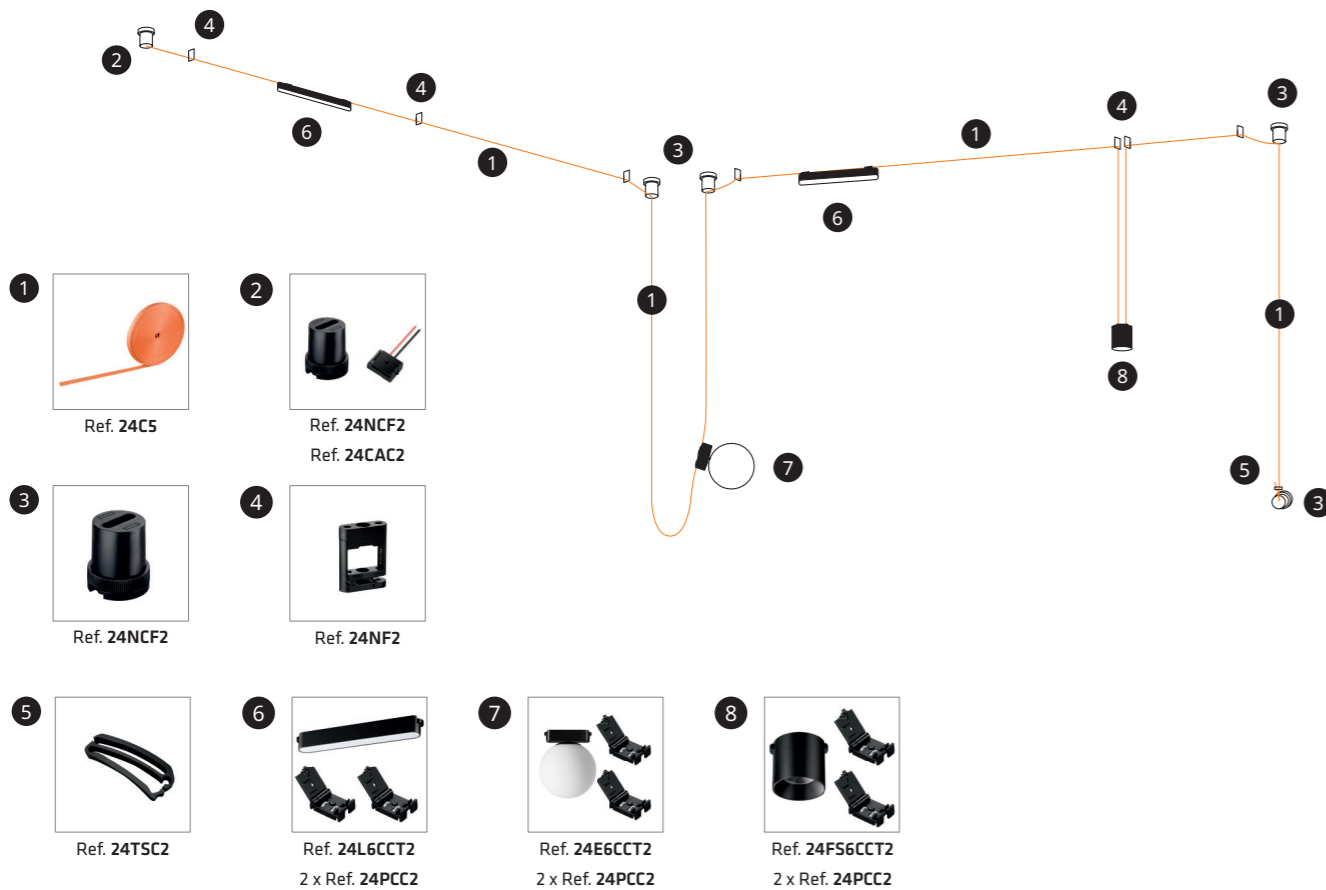

PRO LIMBO Woven track can be used to separate spaces

(ES) La cinta textil puede usarse para separar espacios - (IT) Il track tessile può essere utilizzato per separare lo spazio - (PT) A fita têxtil pode ser usado para separar espaços - (FR) Le track textile peut être utilisé pour séparer les espaces

Choose your preferred installation options according to your needs



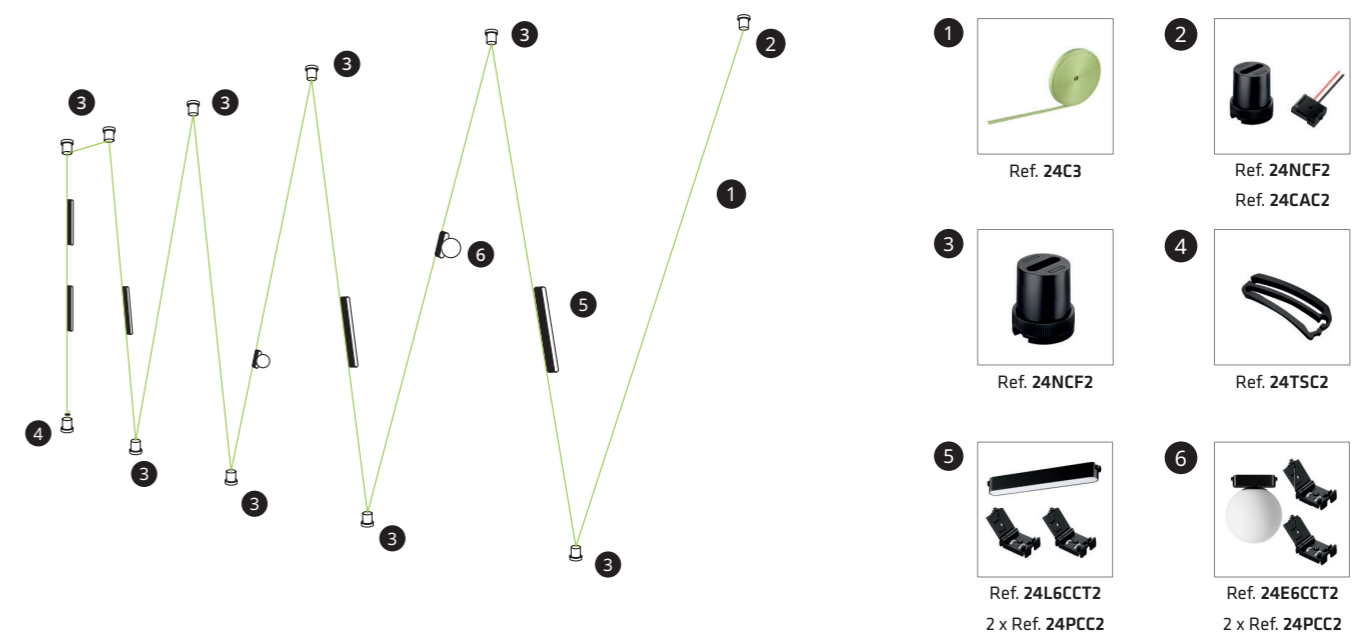





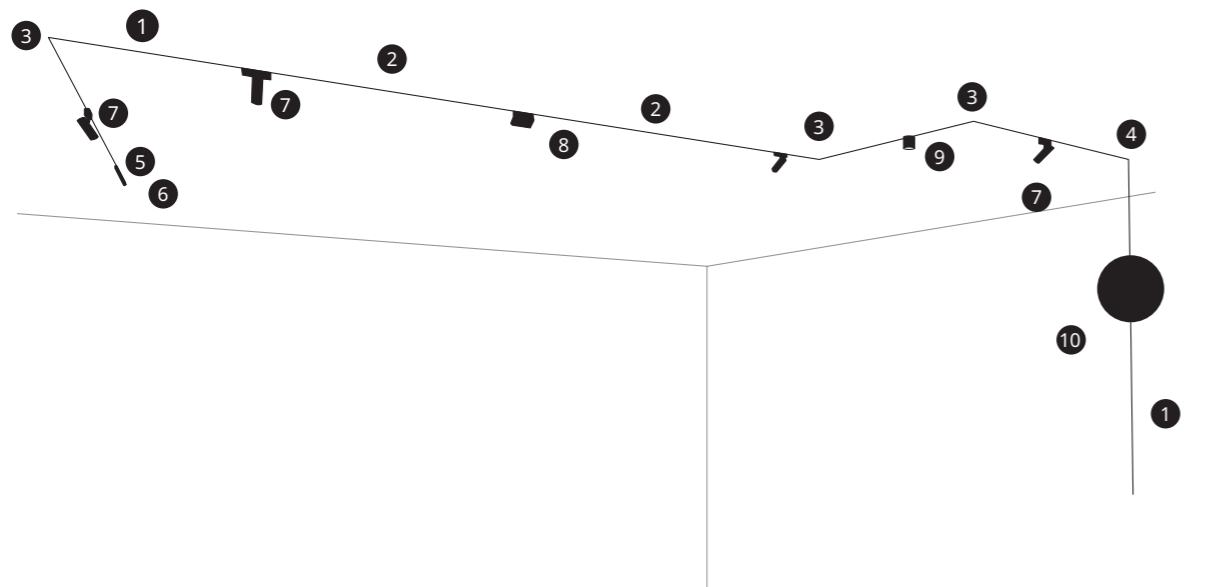

(ES) Elige las opciones de instalación que mejor se adapten a tus necesidades - (IT) Scegli la tua modalità di installazione preferita a seconda dei tuoi bisogni - (PT) Escolha a sua opção de instalação preferida de acordo com as suas necessidades - (FR) Choisissez vos options d'installation préférées selon vos besoins

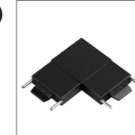

PRO **LIMBO** 24V Ultra thin linear track

(ES) Carril ultrafino 24V - (IT) Binario lineare ultrasottile 24V - (PT) Calha ultrafino 24V - (FR) Rail ultra-mince 24V



- 1  Ref. 24SCR2
- 2  Ref. 24SCL2
- 3  Ref. 24SCLP2
- 4  Ref. 24SCLP2
- 5  Ref. 24D1002
- 6  Ref. 24ECC2
- 7  Ref. 241X6CCT2
- 8  Ref. 240R6CCT2
- 9  Ref. 24F56CCT2
- 10  Ref. 24BP9CCT2

PRO **LIMBO** Ultra thin linear track and woven track can be combined

(ES) El carril ultra fino y la cinta textil pueden combinarse - (IT) Binario lineare ultra sottile e il track tessile possono essere combinati
(PT) Calha ultrafino e fita têxtil podem ser combinados - (FR) Le track textile et rail ultra-mince peuvent être combinés

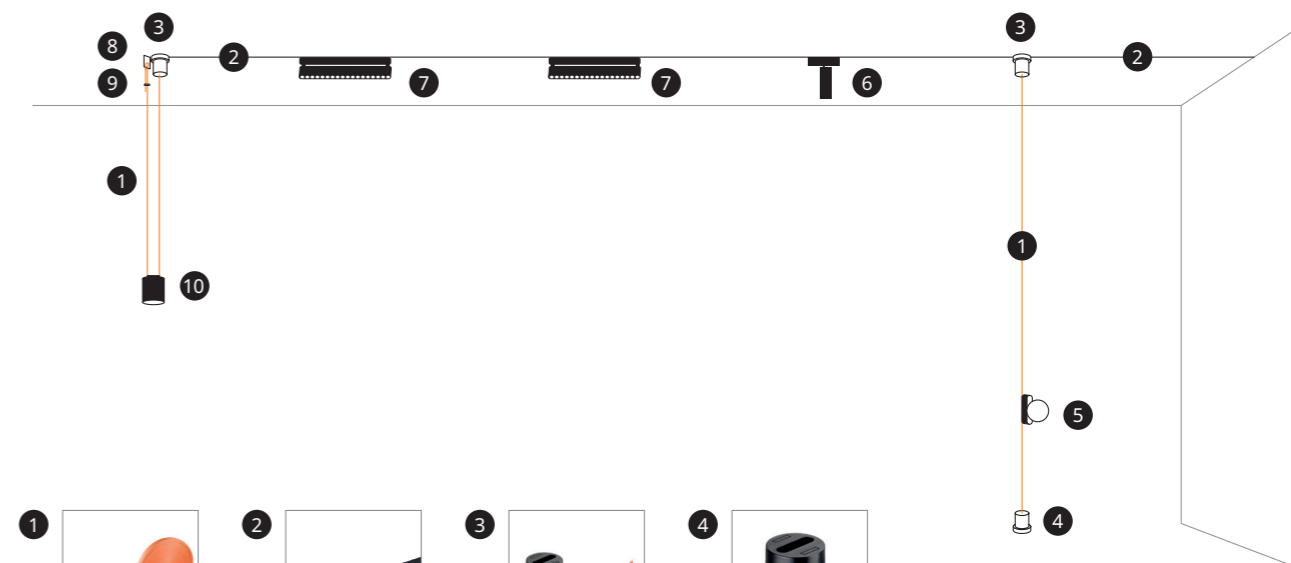

- 1  Ref. 24C5
- 2  Ref. 24SCR2
- 3  Ref. 24NCF2
Ref. 24CAC2
- 4  Ref. 24NCF2
- 5  Ref. 24E6CCT2
2 x Ref. 24PCC2
- 6  Ref. 241X6CCT2
- 7  Ref. 240R12CCT2
- 8  Ref. 24NF2
- 9  Ref. 24T5C2
- 10  Ref. 24F56CCT2
2 x Ref. 24PCC2

PRO LIMBO Ultra thin linear track and woven track can be combined

(ES) El carril ultra fino y la cinta textil pueden combinarse - (IT) Binario lineare ultra sottile e il track tessile possono essere combinati
 (PT) Calha ultrafino e fita têxtil podem ser combinados - (FR) Le track textile et rail ultra-mince peuvent être combinés

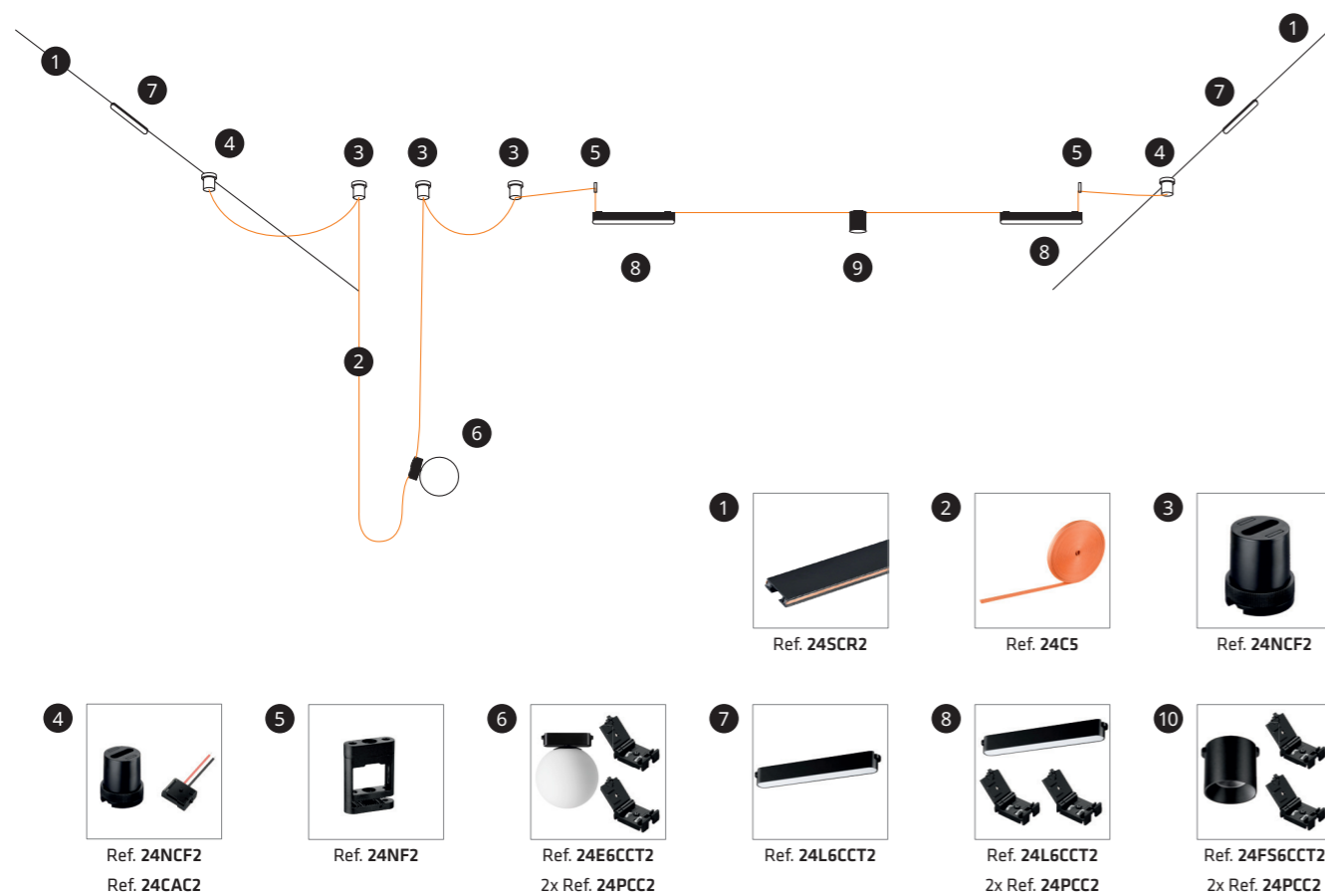

THREELINE 



Limbo.ThreelineGroup.com